

*Vendor-independent, scalable rules (MOSIS SCMOS Rules)*

Design Rules

# MOSIS Scalable CMOS (SCMOS)

(Revision 8.00)

Updated: May 11, 2009

## 1. Introduction

This document defines the official MOSIS scalable CMOS (SCMOS) layout rules. It supersedes all previous revisions.

MOSIS Scalable CMOS (SCMOS) is a set of logical layers together with their design rules, which provide a nearly process- and metric-independent interface to many CMOS fabrication processes available through MOSIS. The designer works in the abstract SCMOS layers and metric unit ("lambda"). He then specifies which process and feature size he wants the design to be fabricated in. MOSIS maps the SCMOS design onto that process, generating the true logical layers and absolute dimensions required by the process vendor. The designer can often submit exactly the same design, but to a different fabrication process or feature size. MOSIS alone handles the new mapping.

By contrast, using a specific vendor's layers and design rules ("vendor rules") will yield a design which is less likely to be directly portable to any other process or feature size. Vendor rules usually need more logical layers than the SCMOS rules, even though both fabricate onto exactly the same process. More layers means more design rules, a higher learning curve for that one process, more interactions to worry about, more complex design support required, and longer layout development times. Porting the design to a new process will be burdensome.

SCMOS designers access process-specific features by using MOSIS-provided abstract layers which implement those features. For example, a designer wishing to use second-poly would use the MOSIS-provided second-poly abstract layer, but must then submit to a process providing for two polysilicon layers. In the same way, designers may access multiple metals, or different types of analog structures such as capacitors and resistors, without having to learn any new set of design rules for the more standard layers such as metal-1. SCMOS is there for portability and simplicity. It is NOT there for fine-tuned layout.

Vendor rules may be more appropriate when seeking maximal use of silicon area, more direct control over analog circuit parameters, or for very large production runs, where the

added investment in development time and loss of design portability is clearly justified. However the advantages of using SCMOS rules may far outweigh such concerns, and should be considered.

---

## 1.1 SCMOS Design Rules

In the SCMOS rules, circuit geometries are specified in the Mead and Conway's lambda based methodology [1]. The unit of measurement, lambda, can easily be scaled to different fabrication processes as semiconductor technology advances.

Each design has a technology-code associated with the layout file. Each technology-code may have one or more associated options added for the purpose of specifying either (a) special features for the target process or (b) the presence of novel devices in the design. At the time of this revision, MOSIS is offering CMOS processes with feature sizes from 1.5 micron to 0.18 micron.

---

## 2. Standard CMOS

The standard CMOS technology accessed by MOSIS is a single polysilicon, double metal, bulk CMOS process with enhancement-mode n-MOSFET and p-MOSFET devices [3].

---

### 2.1. Well Type

The Scalable CMOS (SC) rules support both *n*-well and *p*-well processes. MOSIS recognizes three base technology codes that let the designer specify the well type of the process selected. SCN specifies an *n*-well process, SCP specifies a *p*-well process, and SCE indicates that the designer is willing to utilize a process of either *n*-well or *p*-well.

An SCE design must provide both a drawn *n*-well and a drawn *p*-well; MOSIS will use the well that corresponds to the selected process and ignore the other well. As a convenience, SCN and SCP designs may also include the other well (*p*-well in an SCN design or *n*-well in an SCP design), but it will always be ignored.

MOSIS currently offers only *n*-well processes or foundry-designated twin-well processes that from the design and process flow standpoints are equivalent to *n*-well processes. These twin-well processes may have options (deep *n*-well) that provide independently isolated *p*-wells. For all of these processes at this time use the technology code SCN. SCP is currently not supported, and SCE is treated exactly as SCN.

---

## 2.2. SCMOS Options

SCMOS options are used to designate projects that use additional layers beyond the standard single-poly, double metal CMOS. Each option is called out with a designator that is appended to the basic technology-code. Please note that not all possible combinations are available. The current list is shown in Table 1.

MOSIS has not issued SCMOS design rules for some vendor-supported options. For example, any designer using the SCMOS rules who wants the TSMC Thick\_Top\_Metal must draw the top metal to comply with the TSMC rules for that layer. Questions about other non-SCMOS layers should be directed to support@mosis.com.

Table 1: SCMOS Technology Options

Designation	Long Form	Description
E	Electrode	Adds a second polysilicon layer (poly2) that can serve either as the upper electrode of a poly capacitor or (1.5 micron only) as a gate for transistors
A	Analog	Adds electrode (as in E option), plus layers for vertical NPN transistor pbase
3M	3 Metal	Adds second via (via2) and third metal (metal3) layers
4M	4 Metal	Adds 3M plus third via (via3) and fourth metal (metal4) layers
5M	5 Metal	Adds 4M plus fourth via (via4) and fifth metal (metal5) layers
6M	6 Metal	Adds 5M plus fifth via (via5) and sixth metal (metal6) layers
LC	Linear Capacitor	Adds a cap_well layer for linear capacitors
PC	Poly Cap	Adds poly_cap, a different layer for linear capacitors
SUBM	Sub-Micron	Uses revised layout rules for better fit to sub-micron processes (see section 2.4)
DEEP	Deep	Uses revised layout rules for better fit to deep sub-micron processes (see section 2.4)

For options available to specific processes, see Tables 2a and 2b.

Table 2a: MOSIS SCMOS-Compatible Mappings

Foundry	Process	Lambda (micro-meters)	Options
ON Semi	C5F/N (0.5 micron <i>n</i> -well)	0.35	SCN3M, SCN3ME
TSMC	0.35 micron 2P4M (4 Metal Polycided, 3.3 V/5 V)	0.25	SCN4ME
TSMC	0.35 micron 1P4M (4 Metal Silicided, 3.3 V/5 V)	0.25	SCN4M

Table 2b: MOSIS SCMOS\_SUBM-Compatible Mappings

Foundry	Process	Lambda (micro-meters)	Options
ON Semi	C5F/N (0.5 micron <i>n</i> -well)	0.30	SCN3M_SUBM, SCN3ME_SUBM
TSMC	0.35 micron 2P4M (4 Metal Polycided, 3.3 V/5 V)	0.20	SCN4ME_SUBM
TSMC	0.35 micron 1P4M (4 Metal Silicided, 3.3 V/5 V)	0.20	SCN4M_SUBM
TSMC	0.25 micron 5 Metal 1 Poly (2.5 V/3.3 V)	0.15	SCN5M_SUBM
TSMC	0.18 micron 6 Metal 1 Poly (1.8 V/3.3 V)	0.10	SCN6M_SUBM

Table 2c: MOSIS SCMOS\_DEEP-Compatible Mappings

Foundry	Process	Lambda (micro-meters)	Options
TSMC	0.25 micron 5 Metal 1 Poly (2.5 V/3.3 V)	0.12	SCN5M_DEEP
TSMC	0.18 micron 6 Metal 1 Poly (1.8 V/3.3 V)	0.09	SCN6M_DEEP

### 2.3. SCMOS-Compatible Processes

MOSIS currently offers the fabrication processes shown above in Tables 2a, 2b, and 2c. For each process the list of appropriate SCMOS technology-codes is shown.

### 2.4. SCMOS\_SUBM and SCMOS\_DEEP Rules

The SCMOS layout rules were historically developed for 1.0 to 3.0 micron processes. To take full advantage of sub-micron processes, the SCMOS rules were revised to create SCMOS\_SUBM. By increasing the lambda size for some rules (those that didn't shrink as fast in practice as did the overall scheme of things), the sub-micron rules allow for use of a smaller value of lambda, and better fit to these small feature size processes.

The SCMOS\_SUBM rules were revised again at the 0.25 micron regime to better fit the typical deep submicron processes, creating the SCMOS\_DEEP variant.

Table 3a lists the differences between SCMOS and SCMOS sub-micron. Table 3b lists the differences between SCMOS sub-micron and SCMOS deep.

Table 3a: SCMOS and SCMOS Sub-micron Differences

Rule	Description	SCMOS	SCMOS sub-micron
1.1, 17.1	Well width	10	12
1.2, 17.2	Well space (different potential)	9	18
2.3	Well overlap	5	6

	(space) to transistor		
3.2	Poly space	2	3
5.3, 6.3	Contact space	2	3
5.5b	Contact to Poly space to Poly	4	5
7.2	Metal1 space	2	3
7.4	Minimum space (when metal line is wider than 10 lambda)	4	6
8.5	Via on flat	2	Unrestricted
11.1	Poly2 width	3	7
11.3	Poly2 overlap	2	5
11.5	Space to Poly2 contact	3	6
13.2	Poly2 contact space	2	3
15.1	Metal3 width (3 metal process only)	6	5
15.2	Metal3 space (3 metal process only)	4	3
15.4	Minimum space (when metal line is wider than 10 lambda) (3 metal process only)	8	6
17.3	Minimum spacing to external Active	5	6
17.4	Minimum overlap of Active	5	6

Table 3b: SCMOS Sub-micron and SCMOS Deep Differences

Rule	Description	SCMOS sub-micron	SCMOS DEEP
3.2	Poly space over field	3	3

3.2.a	Poly space over Active		4
3.3	Minimum gate extension of Active	2	2.5
3.4	Active extension beyond Poly	3	4
4.3	Select overlap of Contact	1	1.5
4.4	Select width and space (p+ to p+ or n+ to n+)	2	4
5.3, 6.3	Contact spacing	3	4
8.1	Via width	2	3
9.2	Metal2 space	3	4
9.4	Minimum space (when metal line is wider than 10 lambda)	6	8
14.1	Via2 width	2	3
15.2	Metal3 space	3	4
15.4	Minimum space (when metal line is wider than 10 lambda) (for 4+ metal processes)	6	8
21.1	Via3 width	2	3
22.2	Metal4 space (for 5+ metal processes)	3	4
22.4	Minimum space (when metal line is wider than 10 lambda)	6	8
25.1	Exact size	2 x 2	3 x 3
26.2	Metal5 space	3	4
26.3	Minimum overlap of Via4	1	2

	(for 5 metal process only)		
26.4	Via4 overlap	6	8
29.1	Exact size	3 x 3	4 x 4
30.3	Minimum overlap of Via5	1	2

### 3. CIF and GDS Layer Specification

A user design submitted to MOSIS using the SCMOS rules can be in either Calma GDSII format [2] or Caltech Intermediate Form (CIF version 2.0) [1]. The two are completely interchangeable. Note that all submitted CIF and GDS files have already been scaled before submission, and are always in absolute metric units -- never in lambda units.

GDSII is a binary format, while CIF is a plain ASCII text. For detailed syntax and semantic specifications of GDS and CIF, refer to [2] and [1] respectively.

In GDS format, a design layer is specified as a number between 0 and 255. MOSIS SCMOS now reserves layer numbers 21 through 62, inclusive, for drawn layout. Layers 0 through 20 plus layers 63 and above can be used by designers for their own purposes and will be ignored by MOSIS.

Users should be aware that there is only one contact mask layer, although several separate layers were defined and are retained for backward compatibility. A complete list of SCMOS layers is shown in Table 4, along with a list by technology code in Table 5.

Table 4: SCMOS Layer Map

Layer	GDS	CIF	CIF Synonym	Rule Section	Notes
N_WELL	42	CWN		1	
P_WELL	41	CWP		1	SCPxx
CAP_WELL	59	CWC		17, 18	SCN3MLC
ACTIVE	43	CAA		2	
THICK_ ACTIVE	60	CTA		24	SCN4M (TSMC only), SCN4ME, SCN5M, SCN6M



PBASE	58	CBA		16	SCNA
POLY_CAP1	28	CPC		23	SCNPC
POLY	46	CPG		3	
SILICIDE_BLOCK	29	CSB		20	SCN3M, SCN4M (TSMC only), SCN5M, SCN6M
N_PLUS_SELECT	45	CSN		4	
P_PLUS_SELECT	44	CSP		4	
POLY2	56	CEL		11, 12, 13	SCNE, SCNA, SCN3ME, SCN4ME
HI_RES_IMPLANT	34	CHR		27	SCN3ME
CONTACT	25	CCC	CCG	5, 6, 13	
POLY_CONTACT	47	CCP		5	Can be replaced by CONTACT
ACTIVE_CONTACT	48	CCA		6	Can be replaced by CONTACT
POLY2_CONTACT	55	CCE		13	SCNE, SCNA, SCN3ME, SCN4ME Can be replaced by CONTACT.
METAL1	49	CM1	CMF	7	
VIA	50	CV1	CVA	8	
METAL2	51	CM2	CMS	9	
VIA2	61	CV2	CVS	14	SCN3M, SCN3ME, SCN3MLC, SCN4M, SCN4ME, SCN5M, SCN6M
METAL3	62	CM3	CMT	15	SCN3M, SCN3ME, SCN3MLC, SCN4M, SCN4ME, SCN5M, SCN6M

VIA3	30	CV3	CVT	21	SCN4M, SCN4ME, SCN5M, SCN6M
METAL4	31	CM4	CMQ	22	SCN4M, SCN4ME, SCN5M, SCN6M
CAP_TOP_METAL	35	CTM		28	SCN5M, SCN6M
VIA4	32	CV4	CVQ	25	SCN5M, SCN6M
METAL5	33	CM5	CMP	26	SCN5M, SCN6M
VIA5	36	CV5		29	SCN6M
METAL6	37	CM6		30	SCN6M
DEEP_N_WELL	38	CDNW		31	SCN5M, SCN6M
GLASS	52	COG		10	
PADS	26	XP			Optional non-fab layer used solely to highlight the bonding pads.
Comments	--	CX			Comments

Table 5: Technology-code Map

Technology code with link to layer map	Layers
SCNE	N_well, Active, N_select, P_select, Poly, Poly2, Contact, Metal1, Via, Metal2, Glass
SCNA	N_well, Active, N_select, P_select, Poly, Poly2, Contact, Pbase, Metal1, Via, Metal2, Glass
SCNPC	N_well, Active, N_select, P_select, Poly_cap, Poly, Contact, Metal1, Via, Metal2, Glass
SCN3M	N_well, Active, N_select, P_select, Poly, Hi_Res_Implant, Contact,

	Metal1, Via, Metal2, Via2, Metal3, Glass
SCN3ME	N_well, Active, N_select, P_select, Poly, Poly2, Hi_Res_Implant, Contact, Metal1, Via, Metal2, Via2, Metal3, Glass
SCN3MLC	N_well, Cap_well, Active, N_select, P_select, Poly, Silicide block, Contact, Metal1, Via, Metal2, Via2, Metal3, Glass
SCN4M	N_well, Active, Thick_Active (TSMC only), N_select, P_select, Poly, Contact, Metal1, Via, Metal2, Via2, Metal3, Via3, Metal4, Glass
SCN4ME	N_well, Active, Thick_Active, N_select, P_select, Poly, Poly2, Contact, Metal1, Via, Metal2, Via2, Metal3, Via3, Metal4, Glass
SCN5M	N_well, Active, Thick_Active, N_select, P_select, Poly, Silicide block, Contact, Metal1, Via, Metal2, Via2, Metal3, Via3, Metal4, Cap_Top_Metal, Via4, Metal5, Deep_N_Well, Glass
SCN6M	N_well, Active, Thick_Active, N_select, P_select, Poly, Silicide block, Contact, Metal1, Via, Metal2, Via2, Metal3, Via3, Metal4, Via4, Metal5, Cap_Top_Metal, Via5, Metal6, Deep_N_Well, Glass

---

#### 4. Minimum Density Rule

Many fine-featured processes utilize CMP (Chemical-Mechanical Polishing) to achieve planarity. Currently, for MOSIS, the ON Semi 0.50 micron and all the 0.35 micron (and smaller) processes are in this category. Effective CMP requires that the variations in feature density on layer be restricted.

See the following for more details.

---

#### 5. Process-Induced Damage Rules (otherwise known as "Antenna Rules"): General Requirements

The "Antenna Rules" deal with process induced gate oxide damage caused when exposed polysilicon and metal structures, connected to a thin oxide transistor, collect charge from the processing environment (e.g., reactive ion etch) and develop potentials sufficiently large to cause Fowler Nordheim current to flow through the thin oxide. Given the known process charge fluence, a figure of exposed conductor area to transistor gate area ratio is determined which guarantees Time Dependent Dielectric Breakdown (TDDB) reliability requirements for the fabricator. Failure to consider antenna rules in a design may lead to either reduced performance in transistors exposed to process induced damage, or may

lead to total failure if the antenna rules are seriously violated.

---

## 6. Support for Arbitrary Via Placement by Process and Technology Codes

Some processes have restrictions on the placement of vias relative to contacts (rule 8.4) and/or relative to poly and active edges (rule 8.5). Other processes allow arbitrary placement of vias over these lower features.

The placement of vias directly over contacts or other, lower vias is known as "stacked vias."

Table 6: Applicability of Rules 8.4 and 8.5

Technology code with link to layer map	Process	8.4 is Waived	8.5 is Waived
SCN3M	ON Semi 0.50 (C5F/N)	Yes	Yes
SCN3ME	ON Semi 0.50 (C5F/N)	Yes	Yes
SCN4M	TSMC 0.35	Yes	Yes
SCN4ME	TSMC 0.35	Yes	Yes
SCN5M	TSMC 0.25	Yes	Yes
SCN6M	TSMC 0.18	Yes	Yes

---

## 7. Half-lambda grid submissions

MOSIS Scalable design rules require that layout is on a  $\frac{1}{2}$  lambda grid. Any other gridding information may change without warning. We will accept and process a design regardless of its actual grid (as though it were completely design-rule legal) using the standard "recipe" for that design rule set.

The fracture process puts all its data onto a grid. As an example, the mask grid size in the case of the TSMC 0.35 micron process is 0.0125 micron on the critical layers and 0.025 micron on the others, and all points in your layout that do not fall onto these grid points are "snapped" to the nearest grid point. Obviously, half a grid is the largest snap distance, applied to points that fall neatly in the middle. The 0.025 fracture grid is  $\frac{1}{8}$  lambda for SCN4ME\_SUBM and  $\frac{1}{10}$  lambda for SCN4ME.

---

## 8. PADS Layer

MOSIS has defined an optional PADS layer to help users tell MOSIS which glass openings are to be bonded and which are not. This optional layer lets you call out only those glass cuts that you want MOSIS to use in generating an automated bonding for your project. When used, PADS should match the glass cuts (or the larger metal pads underneath) for just the selected glass cuts.

Geometry on the PADS layer has absolutely no influence on chip fabrication.

When the PADS layer is not present, MOSIS will analyze the glass cuts to determine which appear to be bonding pads and which do not. For the vast majority of layouts, the PADS layer is unnecessary.

---

## References

[1] C. Mead and L. Conway, *Introduction to VLSI Systems*, Addison-Wesley, 1980

[2] Cadence Design Systems, Inc./Calma. *GDSII Stream Format Manual*, Feb. 1987, Release 6.0, Documentation No. B97E060

[3] N. H. E. Weste and K. Eshraghian, *Principles of CMOS VLSI Design: A System Perspective*, Addison-Wesley, 2nd edition, 1993

---





## SCMOS Layout Rules - DEEP\_N\_WELL for SCMOS\_DEEP (and SUBM)

The DEEP\_N\_WELL layer provides access to the DNW layer in the TSMC 0.18 and 0.25 processes. This provides a layering sometimes called "triple-well" in which an n-well sits in the p-substrate, and then a p-well sits fully inside of the n-well; it is then possible to construct NMOS devices inside of that isolated p-well. The isolated p-well is surrounded by a fence of standard N\_WELL (around its periphery), and by DEEP\_N\_WELL underneath. The N\_WELL fence makes direct electrical contact with the DEEP\_N\_WELL plate beneath it.

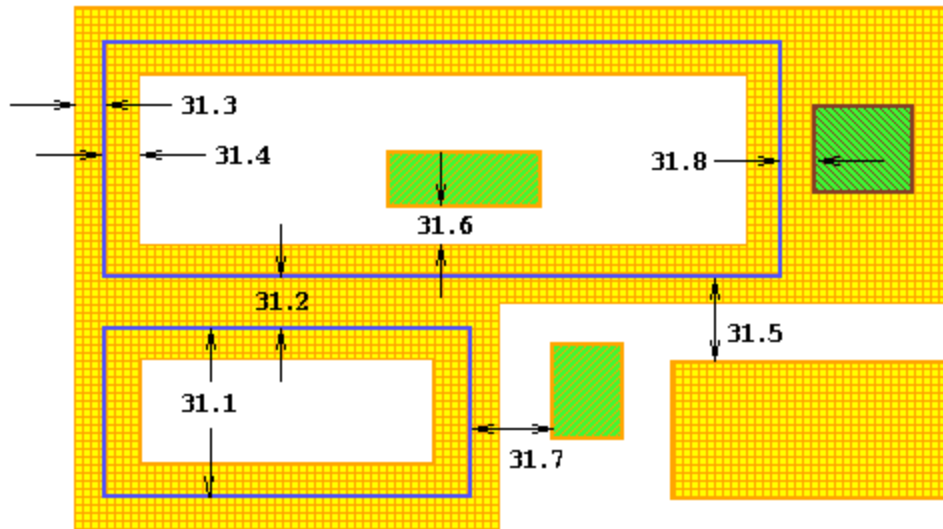
DEEP\_N\_WELL is available in technology codes SCN5M\_SUBM, SCN5M\_DEEP, SCN6M\_SUBM and SCN6M\_DEEP but only where these are to be fabricated on TSMC foundry runs. To gain a better understanding of this layer, the TSMC vendor-rule design rule documentation should be studied.

Rule	Description	Lambda		
		SCMOS	SUBM	DEEP
31.1	Minimum Width, Deep_N_Well	n/a	30	34
31.2	Minimum Spacing, Deep_N_Well to Deep_N_Well	n/a	50	56
31.3	Minimum extension, N_Well beyond Deep_N_Well edge	n/a	15	17
31.4	Minimum overlap, N_Well over Deep_N_Well edge	n/a	20	23
31.5	Minimum spacing, Deep_N_Well to unrelated N_Well	n/a	35	39
31.6	Minimum spacing, N+Active in isolated P-well, to N_Well	n/a	5	6
31.7	Minimum spacing, external N+Active to Deep_N_Well	n/a	30	34
31.8	Minimum spacing, P+Active in N_Well to its Deep_N_Well	n/a	10	13



 N_Well	 N+ Active
 Deep_N_Well	 P+ Active

## SCMOS Layout Rules - Well

Rule	Description	Lambda		
		SCMOS	SUBM	DEEP
1.1	Minimum width	10	12	12
1.2	Minimum spacing between wells at different potential	9	18	18
1.3	Minimum spacing between wells at same potential	6	6	6
1.4	Minimum spacing between wells of different type (if both are drawn)	0	0	0

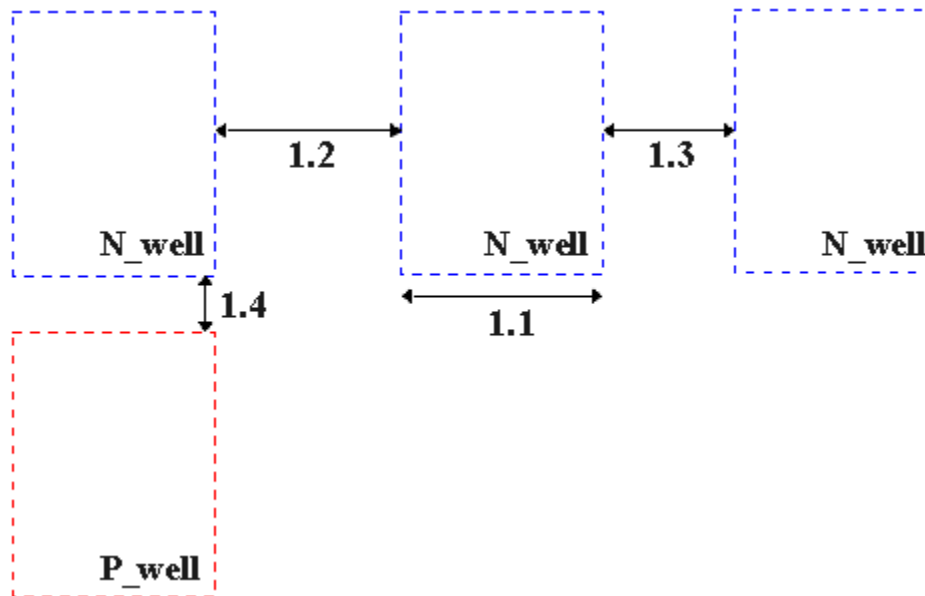



## SCMOS Layout Rules - Capacitor Well

The capacitor well described in this and the next rule only apply to SCN3MLC and SCN3MLC\_SUBM technology codes manufactured on an Agilent/HP AMOS14TB run.

Rule	Description	Lambda		
		SCMOS	SUBM	DEEP
17.1	Minimum width	10	12	n/a
17.2	Minimum spacing	9	18	n/a
17.3	Minimum spacing to external active	5	6	n/a
17.4	Minimum overlap of active	5	6	n/a

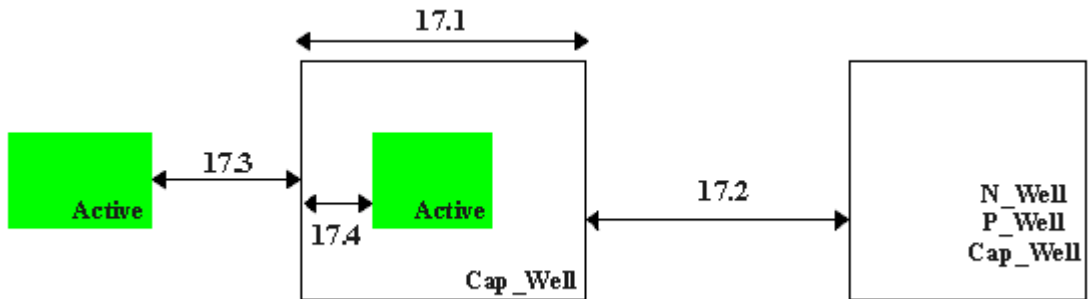

## SCMOS Layout Rules - Linear Capacitor (Linear Capacitor Option)

These rules illustrate the construction of a linear capacitor in a capacitor well. The capacitor itself is the region of overlapped poly and active. The active area is electrically connected to the cap well

Rule	Description	Lambda		
		SCMOS	SUBM	DEEP
18.1	Minimum width	3	3	n/a
18.2	Minimum poly extension of active	2	2	n/a
18.3	Minimum active overlap of poly	3	3	n/a
18.4	Minimum poly contact to active	2	2	n/a
18.5	Minimum active contact to poly	6	6	n/a

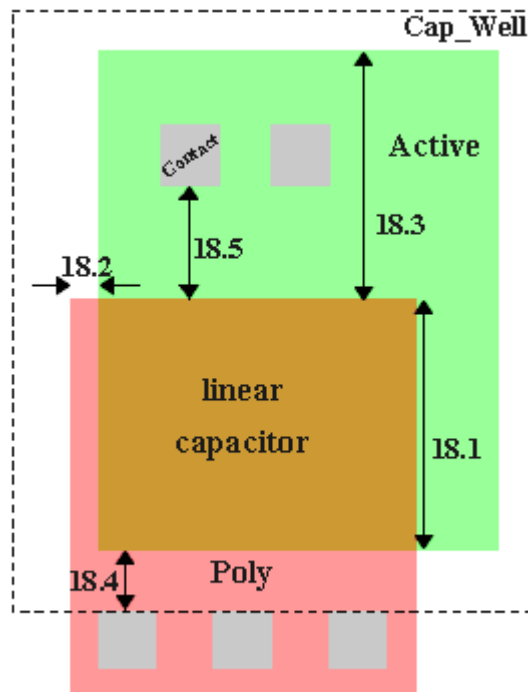

## SCMOS Layout Rules - Active

Rule	Description	Lambda		
		SCMOS	SUBM	DEEP
2.1	Minimum width	3 *	3 *	3
2.2	Minimum spacing	3	3	3
2.3	Source/drain active to well edge	5	6	6
2.4	Substrate/well contact active to well edge	3	3	3
2.5	Minimum spacing between non-abutting active of different implant. Abutting active ("split-active") is illustrated under Select Layout Rules.	4	4	4

\* Note: For analog and critical digital designs, MOSIS recommends the following minimum MOS channel widths (active under poly) for ON Semiconductor designs. Narrower devices, down to design rule minimum, will be functional, but their electrical characteristics will not scale, and their performance is not predictable from MOSIS SPICE parameters.

Process	Design Technology	Design Lambda (micrometers)	Minimum Width (lambda)
AMI_C5F/N	SCN3M, SCN3ME	0.35	9
AMI_C5F/N	SCN3M_SUBM, SCN3ME_SUBM	0.30	10

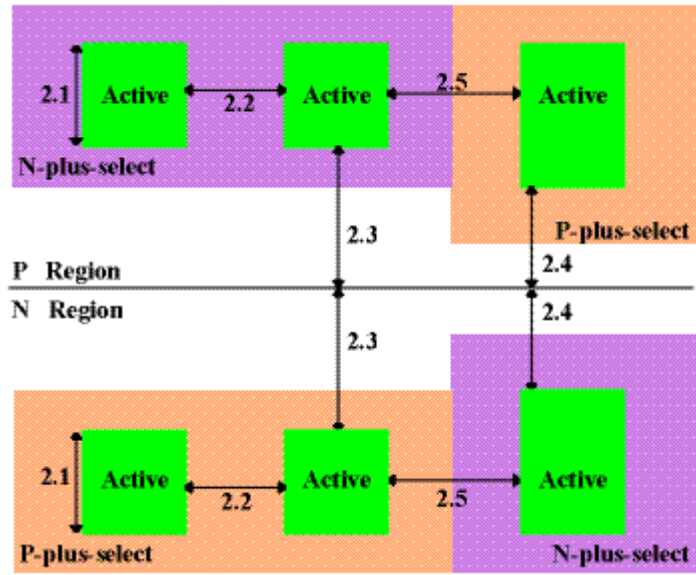

## SCMOS Layout Rules - Thick Active

THICK\_ACTIVE is a layer used for those processes offering two different thicknesses of gate oxide (typically for the layout of transistors that operate at two different voltage levels). The ACTIVE layer is used to delineate all the active areas, regardless of gate oxide thickness. THICK\_ACTIVE is used to mark those ACTIVE areas that will have the thicker gate oxide; ACTIVE areas outside THICK\_ACTIVE will have the thinner gate oxide. THICK\_ACTIVE by itself (not covering any ACTIVE polygon) is meaningless.

Rule	Description	Lambda		
		SCMOS	SUBM	DEEP
24.1	Minimum width	4	4	4
24.2	Minimum spacing	4	4	4
24.3	Minimum ACTIVE overlap	4	4	4
24.4	Minimum space to external ACTIVE	4	4	4
24.5	Minimum poly width in a THICK_ACTIVE gate	3	3	3
24.6	Every ACTIVE region is either entirely inside THICK_ACTIVE or entirely outside THICK_ACTIVE			

## SCMOS Layout Rules - Pbase (Analog Option)

The pbase layer is an active area that is implanted with the pbase implant to form the base of the NPN bipolar transistor. The base contact is enclosed in p-select. The emitter is an n-select region within (and on top of) the base. The entire pbase sits in an *n*-well that is the collector. The collector contact is a well contact, but the overlaps are larger. Active should not be used inside of pbase.

Rule	Description	Lambda		
		SCMOS	SUBM	DEEP
16.1	All active contact	2 x 2	n/a	n/a
16.2	Minimum emitter select overlap of contact	3	n/a	n/a
16.3	Minimum pbase overlap of emitter select	2	n/a	n/a
16.4	Minimum spacing between emitter select and base select	4	n/a	n/a
16.5	Minimum pbase overlap of base select	2	n/a	n/a
16.6	Minimum base select overlap of contact	2	n/a	n/a
16.7	Minimum nwell overlap of pbase	6	n/a	n/a
16.8	Minimum spacing between pbase and collector active	4	n/a	n/a
16.9	Minimum collector active overlap of contact	2	n/a	n/a
16.10	Minimum nwell overlap of collector active	3	n/a	n/a
16.11	Minimum select overlap of collector active	2	n/a	n/a

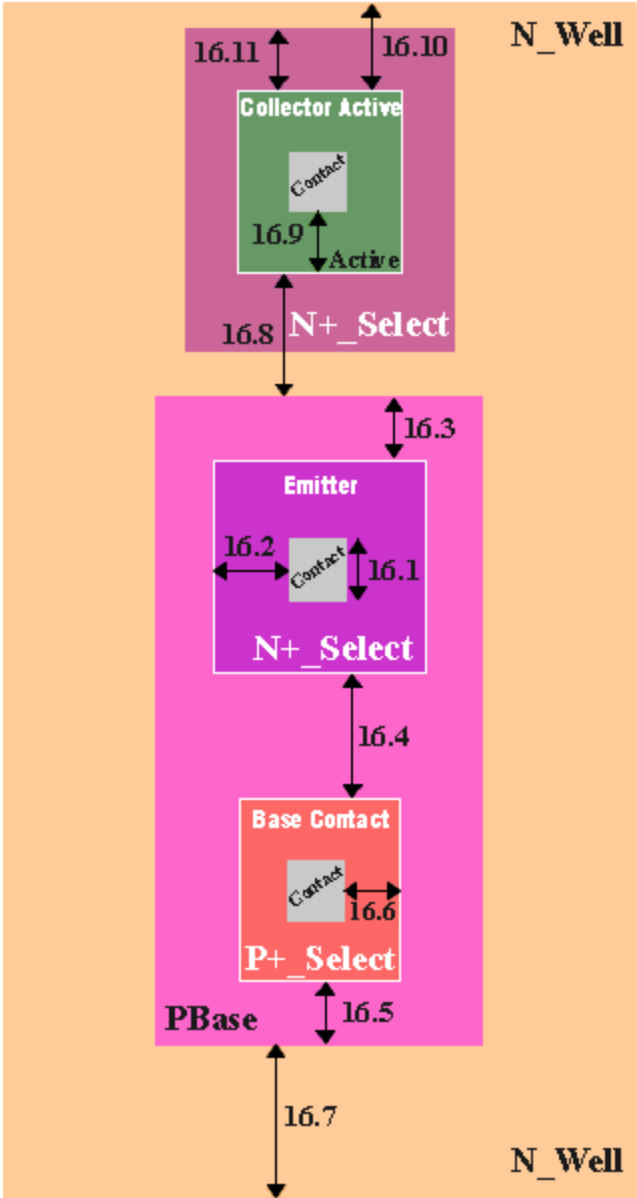

## SCMOS Layout Rules - SCNPC with POLY\_CAP

The two plates of an SCNPC capacitor are POLY and POLY\_CAP1. The POLY\_CAP1 must surround the POLY everywhere; the area of the capacitor is the area of the POLY. POLY is physically on top of POLY\_CAP1, so that contact to the POLY\_CAP1 must be made in the region where it extends beyond the POLY. The capacitor may be in the well or the substrate, but may not straddle a well boundary. The only metal that may cross over a capacitor is the connecting METAL1 wires.

Rule	Description	Lambda		
		SCMOS	SUBM	DEEP
23.1	Minimum POLY_CAP1 width. This is lithographic; the minimum to build a real capacitor is greater than 12 lambda	8	n/a	n/a
23.2	Minimum spacing, POLY_CAP1 to POLY_CAP1 (neighboring capacitor)	4	n/a	n/a
23.3	Minimum spacing, POLY_CAP1 to ACTIVE (all capacitors must be over field)	8	n/a	n/a
23.4	Minimum overlap, POLY_CAP1 over POLY	3	n/a	n/a
23.5	Minimum overlap, POLY_CAP1 over CONTACT	2	n/a	n/a
23.6	Minimum overlap, POLY over CONTACT (in a capacitor only; still 1 lambda elsewhere)	2	n/a	n/a
23.7	Minimum spacing, POLY to CONTACT-to-POLY_CAP1	2	n/a	n/a
23.8	Minimum spacing, unrelated METAL1 to POLY_CAP1	4	n/a	n/a
23.9	Minimum spacing, METAL2 to POLY_CAP1	2	n/a	n/a



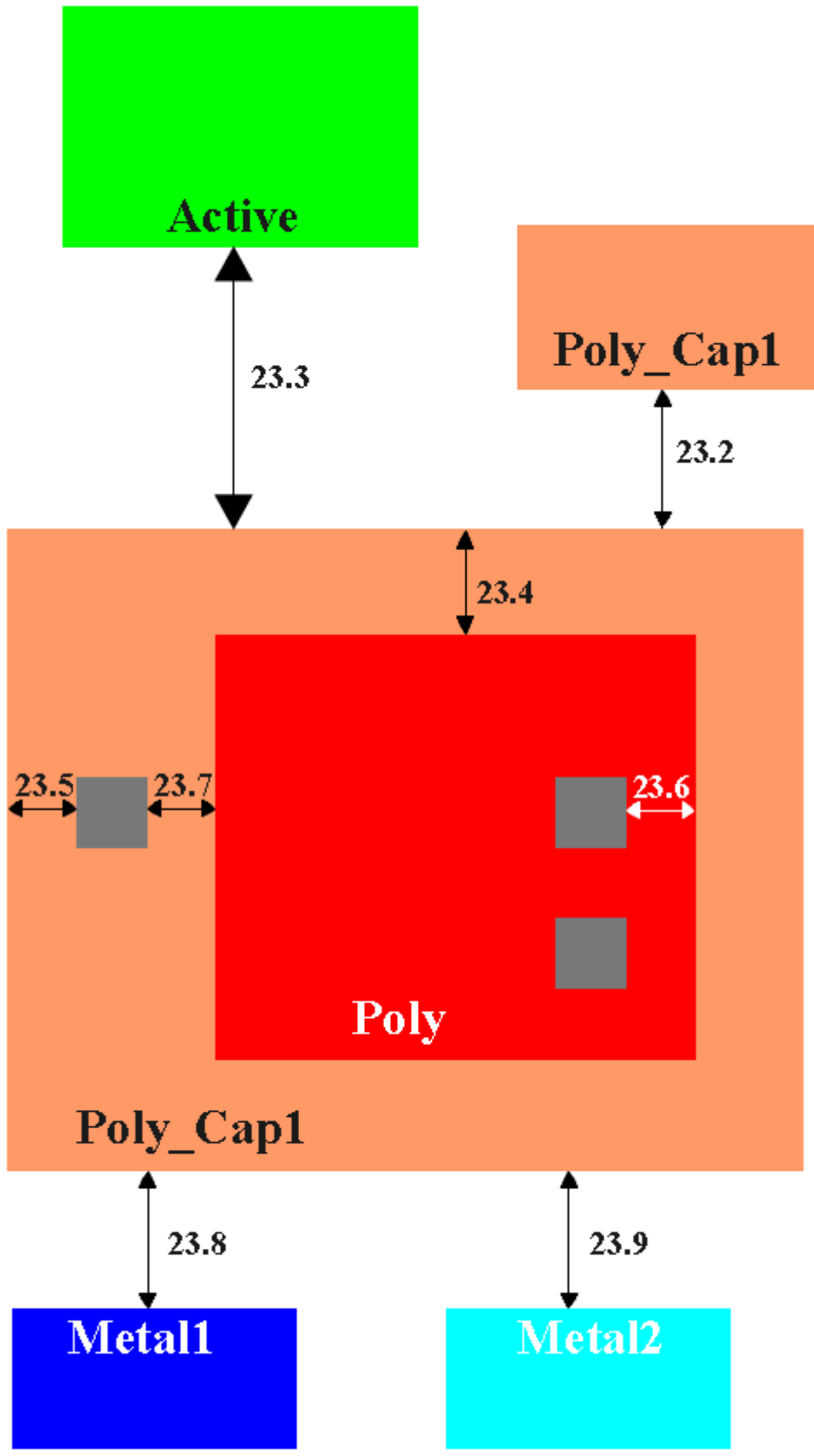

### SCMOS Layout Rules - Poly

Rule	Description	Lambda		
		SCMOS	SUBM	DEEP
3.1	Minimum width	2	2	2
3.2	Minimum spacing over field	2	3	3
3.2.a	Minimum spacing over active	2	3	4
3.3	Minimum gate extension of active	2	2	2.5
3.4	Minimum active extension of poly	3	3	4
3.5	Minimum field poly to active	1	1	1

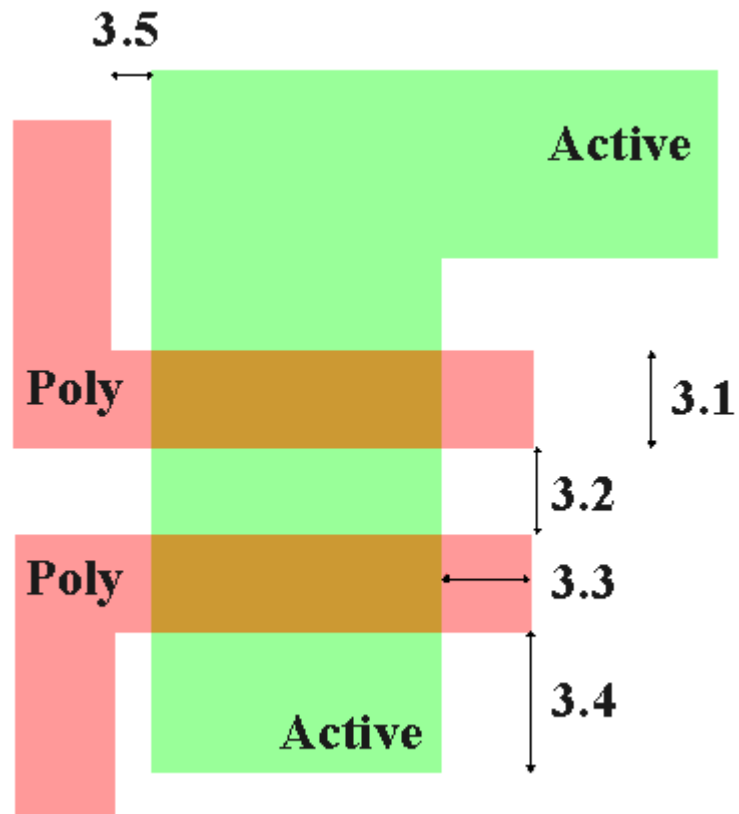

## SCMOS Layout Rules - Silicide Block

Rule	Description	Lambda		
		SCMOS	SUBM	DEEP
20.1	Minimum SB width	4	4	4
20.2	Minimum SB spacing	4	4	4
20.3	Minimum spacing, SB to contact (no contacts allowed inside SB)	2	2	2
20.4	Minimum spacing, SB to external active	2	2	2
20.5	Minimum spacing, SB to external poly	2	2	2
20.6	Resistor is poly inside SB; poly ends stick out for contacts the entire resistor must be outside well and over field			
20.7	Minimum poly width in resistor	5	5	5
20.8	Minimum spacing of poly resistors (in a single SB region)	7	7	7
20.9	Minimum SB overlap of poly or active	2	2	2
20.10	Minimum poly or active overlap of SB	3	3	3
20.11	Minimum spacing, SB to poly (in a single active region)	3	5	5

NOTE: Some processes do not support both silicide block over active and silicide block over poly. Refer to the individual process description pages.

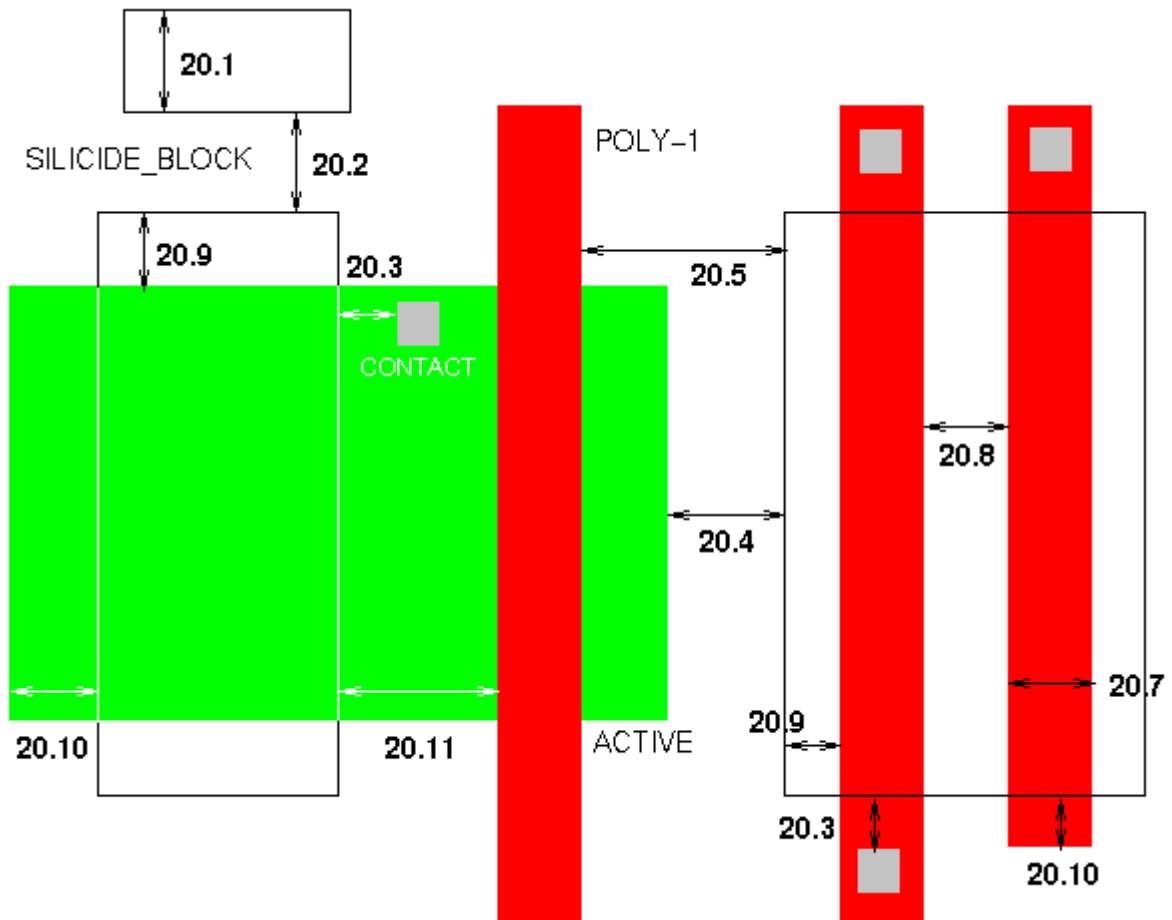

## SCMOS Layout Rules - Select

Rule	Description	Lambda		
		SCMOS	SUBM	DEEP
4.1	Minimum select spacing to channel of transistor to ensure adequate source/drain width	3	3	3
4.2	Minimum select overlap of active	2	2	2
4.3	Minimum select overlap of contact	1	1	1.5
4.4	Minimum select width and spacing (Note: P-select and N-select may be coincident, but must <i>not</i> overlap) (not illustrated)	2	2	4

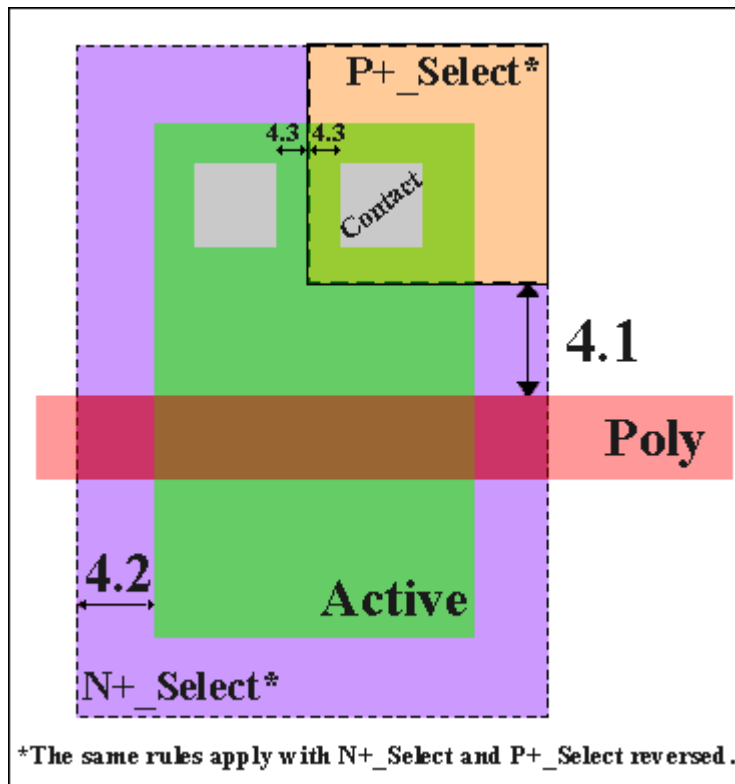

## SCMOS Layout Rules - Poly2 for Capacitor

The poly2 layer is a second polysilicon layer (physically above the standard, or first, poly layer). The oxide between the two polys is the capacitor dielectric. The capacitor area is the area of coincident poly and electrode.

Rule	Description	Lambda		
		SCMOS	SUBM	DEEP
11.1	Minimum width	3	7	n/a
11.2	Minimum spacing	3	3	n/a
11.3	Minimum poly overlap	2	5	n/a
11.4	Minimum spacing to active or well edge (not illustrated)	2	2	n/a
11.5	Minimum spacing to poly contact	3	6	n/a
11.6	Minimum spacing to <i>unrelated</i> metal	2	2	n/a

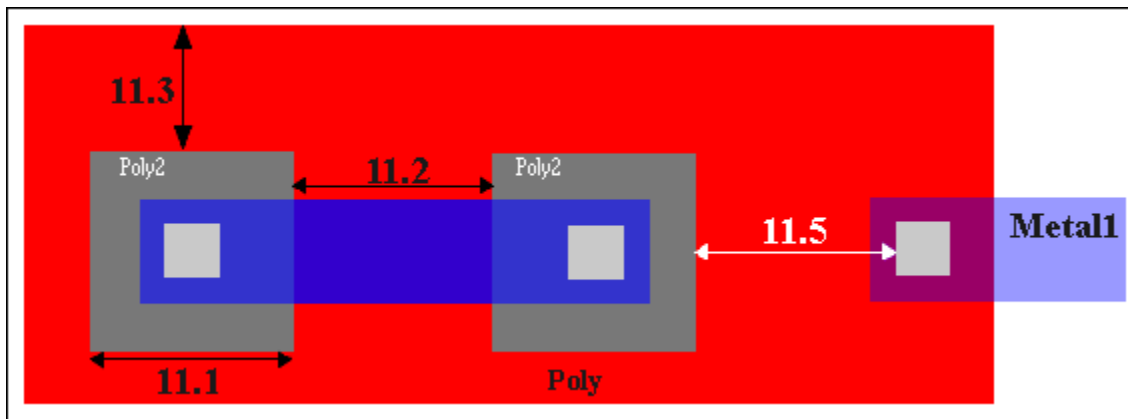

## SCMOS Layout Rules - Poly2 for Transistor Same poly2 layer as for caps

Rule	Description	Lambda		
		SCMOS	SUBM	DEEP
12.1	Minimum width	2	2	n/a
12.2	Minimum spacing	3	3	n/a
12.3	Minimum electrode gate overlap of active	2	2	n/a
12.4	Minimum spacing to active	1	1	n/a
12.5	Minimum spacing or overlap of poly	2	2	n/a
12.6	Minimum spacing to poly or active contact	3	3	n/a

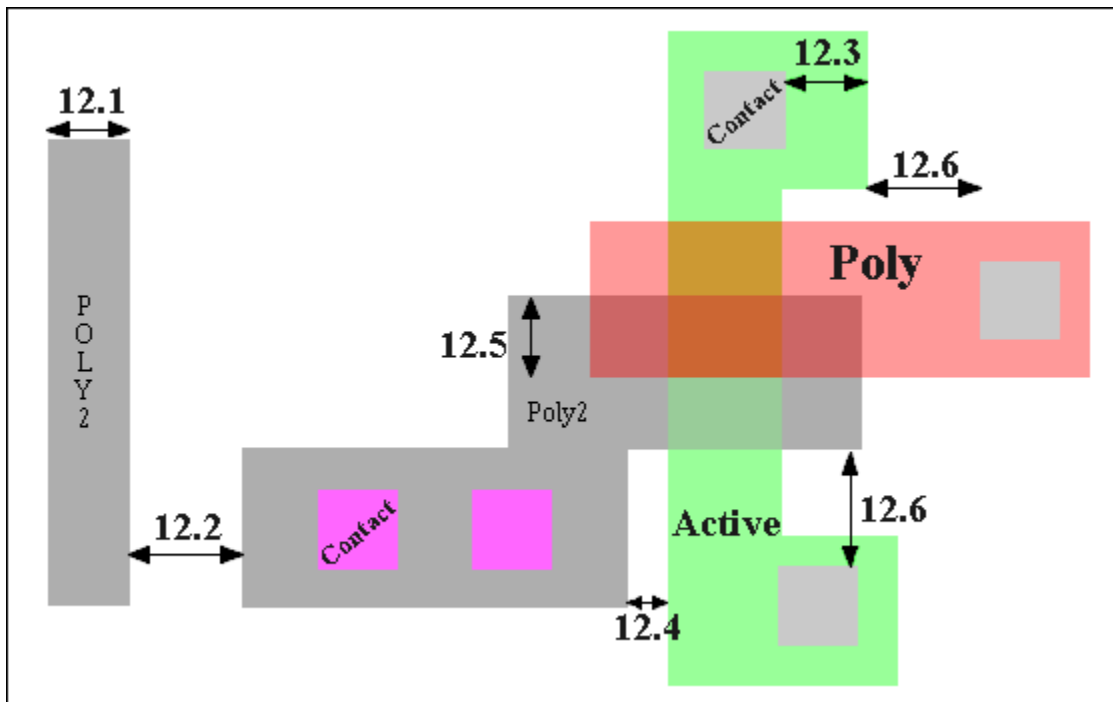

## SCMOS Layout Rules - Poly2 Contact

The poly2 is contacted through the standard contact layer, similar to the first poly. The overlap numbers are larger, however.

Contacts must be drawn orthogonal to the grid of the layout. Non-Manhattan contacts are not allowed.

Rule	Description	Lambda		
		SCMOS	SUBM	DEEP
13.1	Exact contact size	2 x 2	2 x 2	n/a
13.2	Minimum contact spacing	2	3	n/a
13.3	Minimum electrode overlap (on capacitor)	3	3	n/a
13.4	Minimum electrode overlap (not on capacitor)	2	2	n/a
13.5	Minimum spacing to poly or active	3	3	n/a



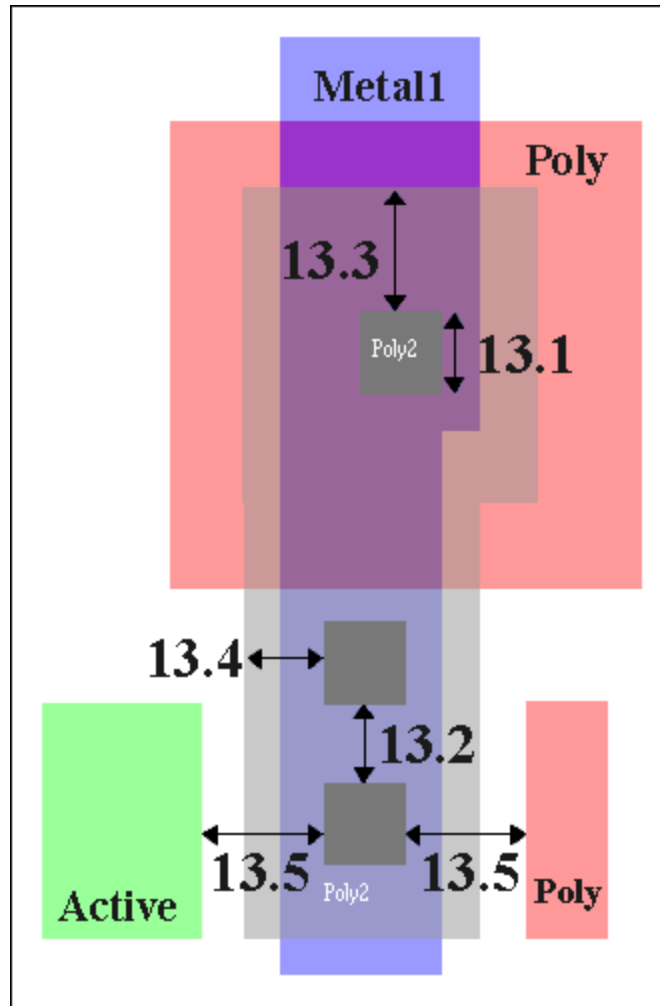

## SCMOS Layout Rules - High Res

Rule	Description	Lambda		
		SCMOS	SUBM	DEEP
27.1	Minimum HR width	4	4	n/a
27.2	Minimum HR spacing	4	4	n/a
27.3	Minimum spacing, HR to contact (no contacts allowed inside HR)	2	2	n/a
27.4	Minimum spacing, HR to external active	2	2	n/a
27.5	Minimum spacing, HR to external poly2	2	2	n/a
27.6	Resistor is poly2 inside HR; poly2 ends stick out for contacts, the entire resistor must be outside well and over field			
27.7	Minimum poly2 width in resistor	5	5	n/a
27.8	Minimum spacing of poly2 resistors (in a single HR region)	7	7	n/a
27.9	Minimum HR overlap of poly2	2	2	n/a

---

## SCMOS Layout Rules - Contact to Poly

On 0.50 micron process (and all finer feature size processes), it is required that all features on the insulator layers (CONTACT, VIA, VIA2) must be of the single standard size; there are no exceptions for pads (or logos, or anything else); large openings must be replaced by an array of standard sized openings. Contacts must be drawn orthogonal to the grid of the layout. Non-Manhattan contacts are not allowed.

If your design cannot tolerate 1.5 lambda contact overlap in 5.2, use the alternative rules which reduce the overlap but increase the spacing to surrounding features. Rules 5.1, 5.3, and 5.4, still apply and are unchanged.

### Simple Contact to Poly

### Alternative Contact to Poly

Rule	Description	Lambda			Rule	Description	Lambda		
		SCMOS	SUBM	DEEP			SCMOS	SUBM	DEEP
5.1	Exact contact size	2x2	2x2	2x2	5.2.b	Minimum poly overlap	1	1	1
5.2	Minimum poly overlap	1.5	1.5	1.5	5.5.b	Minimum spacing to other poly	4	5	5
5.3	Minimum contact spacing	2	3	4	5.6.b	Minimum spacing to active (one contact)	2	2	2
5.4	Minimum spacing to gate of transistor	2	2	2	5.7.b	Minimum spacing to active (many contacts)	3	3	3

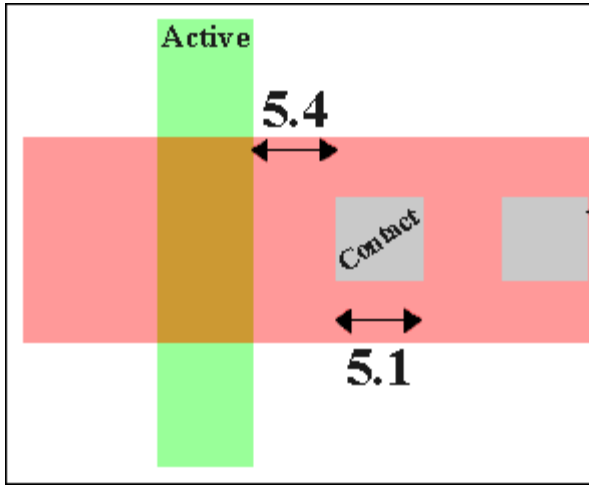

Simple Poly to Contact

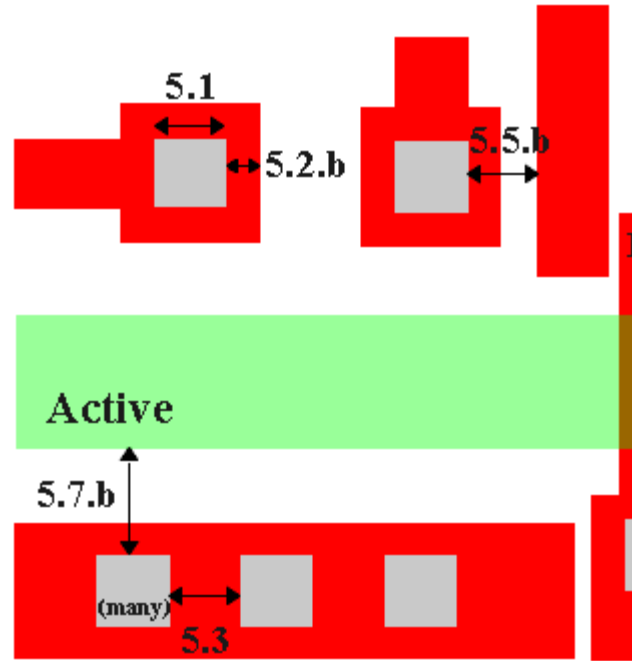

Alternative Contact to Poly

## SCMOS Layout Rules - Contact to Active

If your design cannot handle the 1.5 lambda contact overlap in 6.2, use the alternative rules which reduce the overlap but increase the spacing to surrounding features. Rules 6.1, 6.3, and 6.4, still apply and are unchanged. Contacts must be drawn orthogonal to the grid of the layout. Non-Manhattan contacts are not allowed.

Simple  
Contact to Active

Alternative  
Contact to Active

Rule	Description	Lambda			Rule	Description	Lambda		
		SCMOS	SUBM	DEEP			SCMOS	SUBM	DEEP
6.1	Exact contact size	2x2	2x2	2x2	6.2.b	Minimum active overlap	1	1	1
6.2	Minimum active overlap	1.5	1.5	1.5	6.5.b	Minimum spacing to diffusion active	5	5	5
6.3	Minimum contact spacing	2	3	4	6.6.b	Minimum spacing to field poly (one contact)	2	2	2
6.4	Minimum spacing to gate of transistor	2	2	2	6.7.b	Minimum spacing to field poly (many contacts)	3	3	3
					6.8.b	Minimum spacing to poly contact	4	4	4

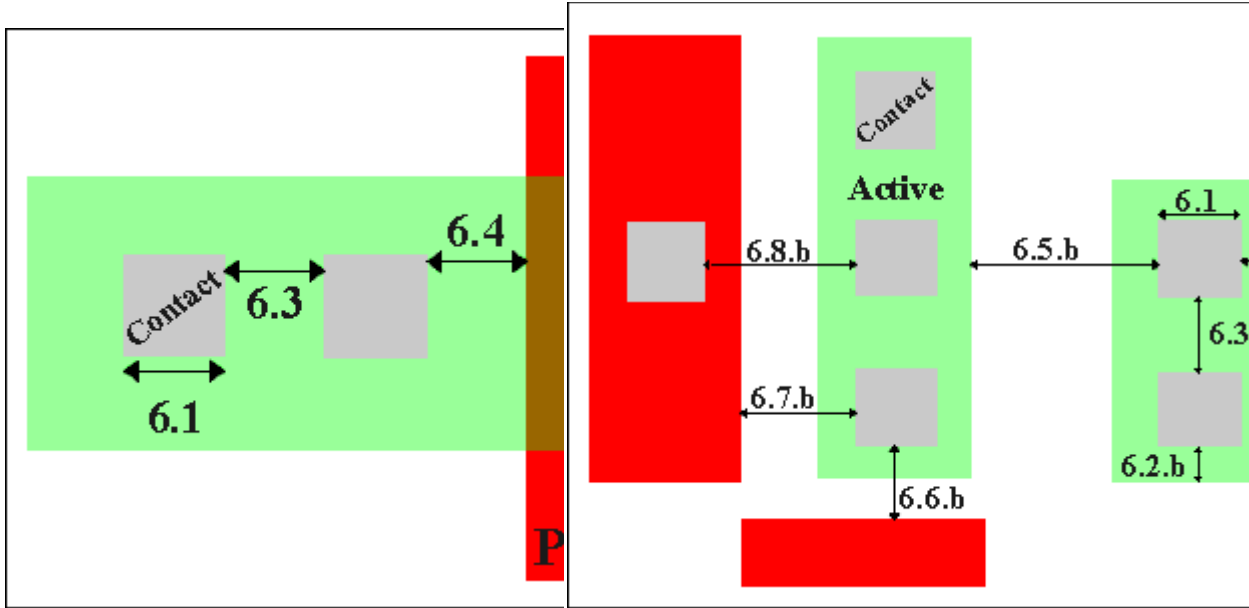

Simple Contact to Active

Alternative Contact to Active



## SCMOS Layout Rules - Via

Vias must be drawn orthogonal to the grid of the layout. Non-Manhattan vias are not allowed.

Rule	Description	Lambda					
		2 Metal Process			3+ Metal Process		
		SCMOS	SUBM	DEEP	SCMOS	SUBM	DEEP
8.1	Exact size	2 x 2	n/a	n/a	2 x 2	2 x 2	3 x 3
8.2	Minimum via1 spacing	3	n/a	n/a	3	3	3
8.3	Minimum overlap by metal1	1	n/a	n/a	1	1	1
8.4	Minimum spacing to contact for technology codes mapped to processes that do not allow stacked vias (SCNA, SCNE, SCN3M, SCN3MLC)	2	n/a	n/a	2	2	n/a
8.5	Minimum spacing to poly or active edge for technology codes mapped to processes that do not allow stacked vias (NOTE: list is not same as for 8.4)	2	n/a	n/a	2	2	n/a

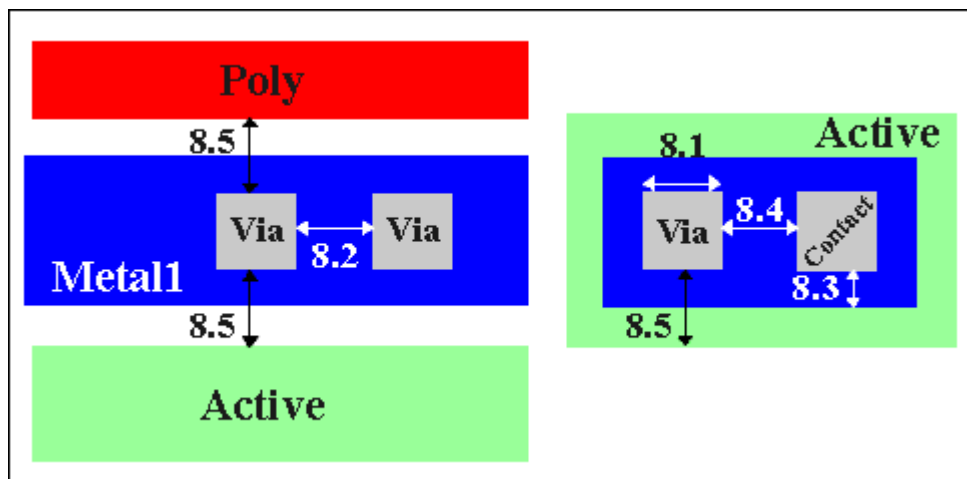



## SCMOS Layout Rules - Metal2

Rule	Description	Lambda					
		2 Metal Process			3+ Metal Process		
		SCMOS	SUBM	DEEP	SCMOS	SUBM	DEEP
9.1	Minimum width	3	n/a	n/a	3	3	3
9.2	Minimum spacing	3	n/a	n/a	3	3	4
9.3	Minimum overlap of via1	1	n/a	n/a	1	1	1
9.4	Minimum spacing when either metal line is wider than 10 lambda	6	n/a	n/a	6	6	8

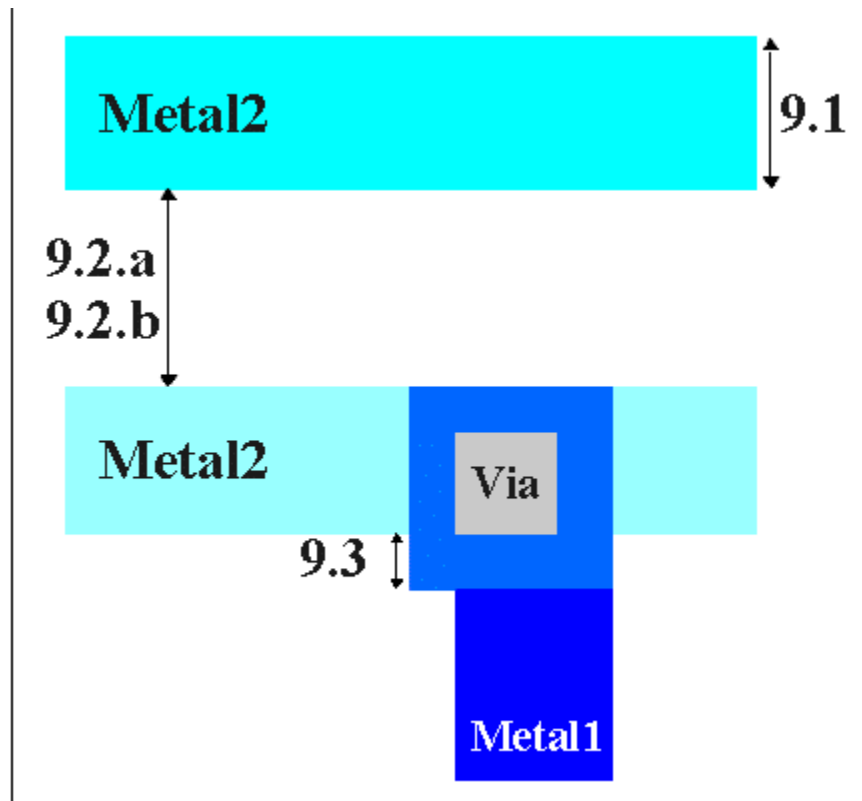

## SCMOS Layout Rules - Via2

Vias must be drawn orthogonal to the grid of the layout. Non-Manhattan vias are not allowed.

Rule	Description	Lambda					
		3 Metal Process			4+ Metal Process		
		SCMOS	SUBM	DEEP	SCMOS	SUBM	DEEP
14.1	Exact size	2x2	2x2	n/a	2x2	2x2	3x3
14.2	Minimum spacing	3	3	n/a	3	3	3
14.3	Minimum overlap by metal2	1	1	n/a	1	1	1
14.4	Via2 may be placed over via1						
14.5	Via2 may be placed over contact						

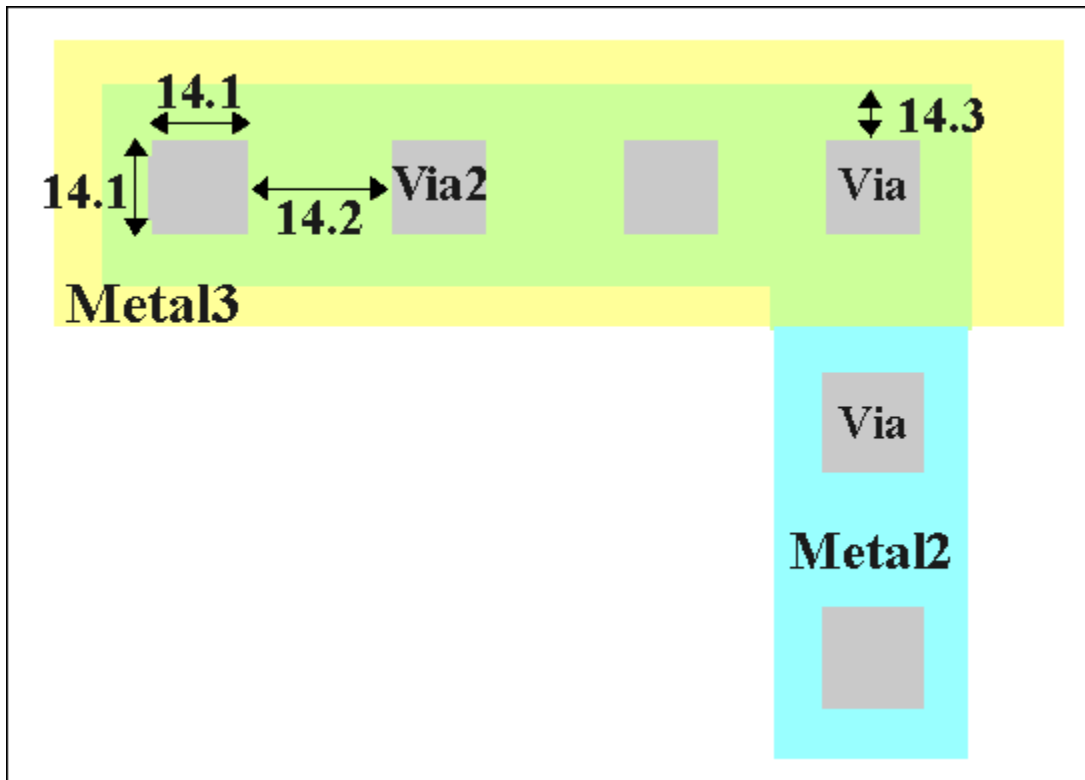

### SCMOS Layout Rules - Metal3

Rule	Description	Lambda					
		3 Metal Process			4+ Metal Process		
		SCMOS	SUBM	DEEP	SCMOS	SUBM	DEEP
15.1	Minimum width	6	5	n/a	3	3	3
15.2	Minimum spacing to metal3	4	3	n/a	3	3	4
15.3	Minimum overlap of via2	2	2	n/a	1	1	1
15.4	Minimum spacing when either metal line is wider than 10 lambda	8	6	n/a	6	6	8

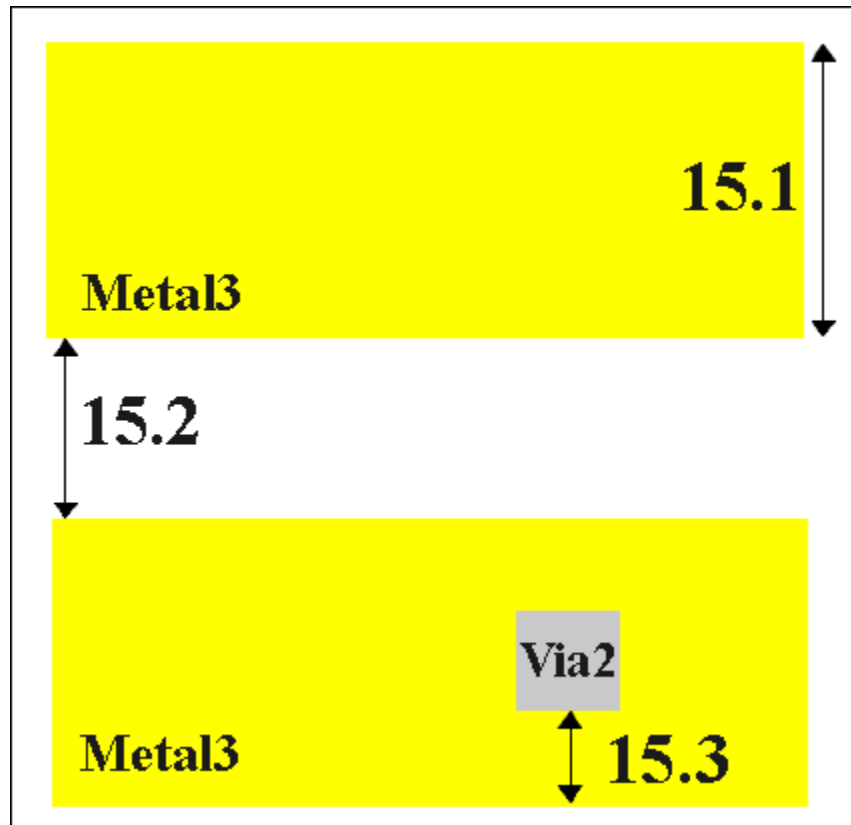

## SCMOS Layout Rules - Via3

Vias must be drawn orthogonal to the grid of the layout. Non-Manhattan vias are not allowed.

Rule	Description	Lambda					
		4 metal Process			5+ Metal Process		
		SCMOS	SUBM	DEEP	SCMOS	SUBM	DEEP
21.1	Exact size	2x2	2x2	n/a	n/a	2x2	3x3
21.2	Minimum spacing	3	3 *	n/a	n/a	3	3
21.3	Minimum overlap by Metal3	1	1	n/a	n/a	1	1

\* Exception: Use lambda=4 for rule 21.2 only when using SCN4M\_SUBM for Agilent/HP GMOS10QA 0.35 micron process

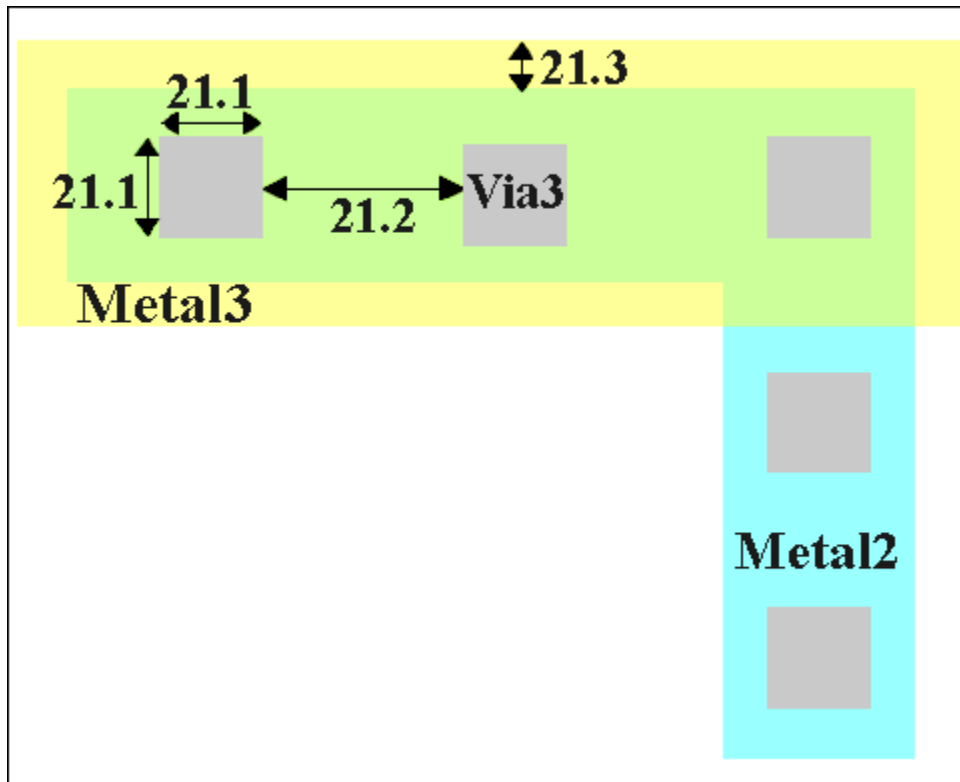

## SCMOS Layout Rules - Metal4

Rule	Description	Lambda					
		4 Metal Process			5+ Metal Process		
		SCMOS	SUBM	DEEP	SCMOS	SUBM	DEEP
22.1	METAL4 width	6	6	n/a	n/a	3	3
22.2	METAL4 space	6	6	n/a	n/a	3	4
22.3	METAL4 overlap of VIA3	2	2	n/a	n/a	1	1
22.4	Minimum spacing when either metal line is wider than 10 lambda	12	12	n/a	n/a	6	8

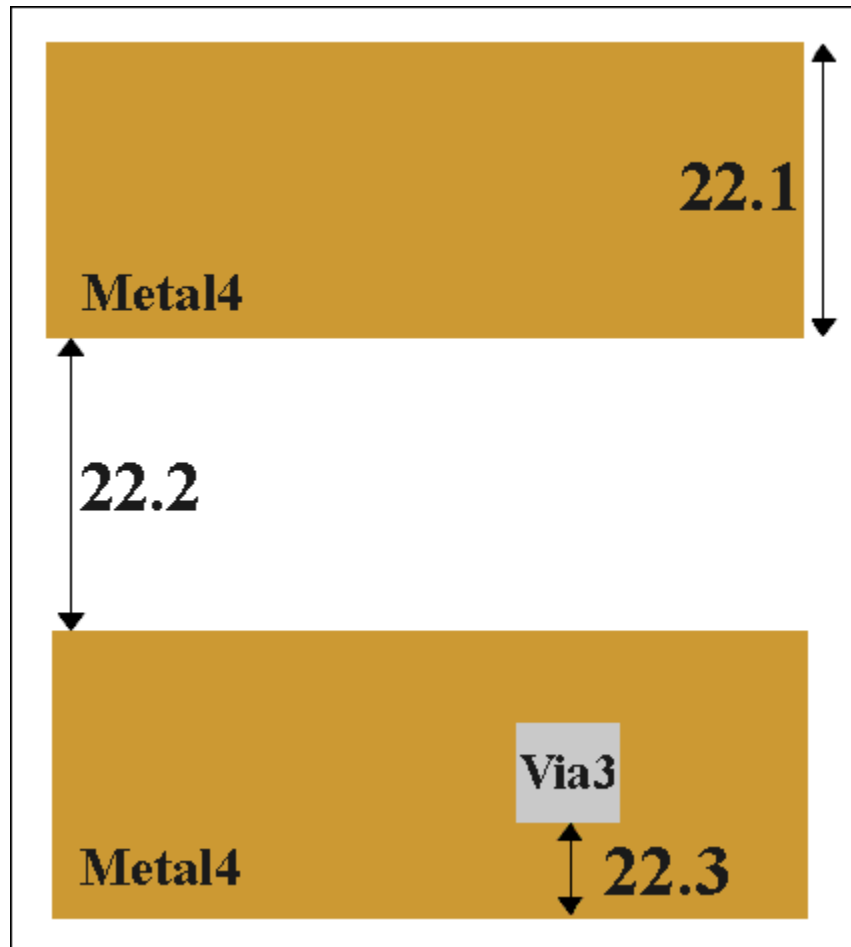

## SCMOS Layout Rules - CAP\_TOP\_METAL for SCMOS\_DEEP (and SUBM)

The CAP\_TOP\_METAL layer is used exclusively for the construction of metal-to-metal capacitors. The bottom plate of the capacitor is one of the regular metal layers, as specified below. CAP\_TOP\_METAL is the upper plate of the capacitor; it is sandwiched physically between the bottom plate metal and the next metal layer above, with a thin dielectric between the bottom plate and the upper (CAP\_TOP\_METAL) plate.

The CAP\_TOP\_METAL can only be contacted from the metal above; the bottom plate metal can be contacted from below or above (subject, in either case, to rule 28.5), and/or by bottom metal extending outside of the capacitor region (rule 28.7). Use of all (legal) upward vias within that region should be maximized. CAP\_TOP\_METAL must always be contained entirely within the bottom plate metal.

Process	Bottom Plate	Top Plate	Top Plate Contact
TSMC_025	METAL4	CAP_TOP_METAL	VIA4 and METAL5
TSMC_018	METAL5	CAP_TOP_METAL	VIA5 and METAL6

Rule	Description	Lambda		
		SCMOS	SUBM	DEEP
28.1	Minimum Width, Capacitor	n/a	40	45
28.2	Minimum Spacing (2 capacitors sharing a single bottom plate)	n/a	12	14
28.3	Minimum bottom metal overlap (including dummy shapes)	n/a	4	5
28.4	Minimum overlap of via	n/a	3	3
28.5	Minimum spacing to bottom metal via	n/a	4	5
28.6	Minimum bottom metal overlap of its via	n/a	2	2

28.7	Rule applicability region extends beyond bottom plate	n/a	25	25
28.8	Minimum width, dummy shapes (having no vias)	n/a	4	5
28.9	Minimum bottom plate to other bottom plate metal	n/a	8	9
28.10	Minimum via separation, on CAP_TOP_METAL	n/a	20	23
28.11	Minimum (upward) via separation on bottom metal	n/a	40	45
28.12	Maximum CAP_TOP_METAL width and length	n/a	30 um	
28.13	Maximum bottom metal plate width and length	n/a	35 um	
28.14	No vias from bottom plate downward, directly under top plate CAP_TOP_METAL; dummy metal shapes under capacitor region, discouraged.			
28.15	No active or passive circuitry under capacitor region			

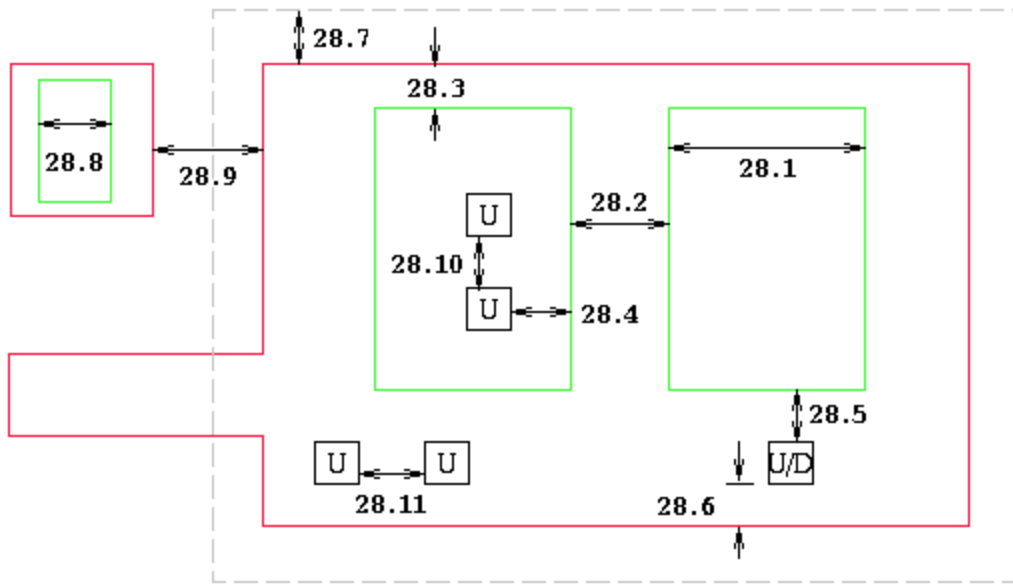

- |   |   |
|---|---|
| <span style="border: 1px solid green; display: inline-block; width: 15px; height: 10px; vertical-align: middle;"></span> Cap_Top_Metal                      | <span style="border: 1px solid black; padding: 2px; display: inline-block; width: 15px; height: 10px; vertical-align: middle;">U</span> Via to higher metal (up)                        |
| <span style="border: 1px solid red; display: inline-block; width: 15px; height: 10px; vertical-align: middle;"></span> Bottom plate metal                   | <span style="border: 1px solid black; padding: 2px; display: inline-block; width: 15px; height: 10px; vertical-align: middle;">D</span> Via to lower metal (down)                       |
| <span style="border: 1px dashed black; display: inline-block; width: 15px; height: 10px; vertical-align: middle;"></span> Rule 28 (vias) within this region | <span style="border: 1px solid black; padding: 2px; display: inline-block; width: 15px; height: 10px; vertical-align: middle;">U/D</span> Rule applies to both upward and downward vias |



## SCMOS Layout Rules - Via4 (SUBM and DEEP)

Vias must be drawn orthogonal to the grid of the layout. Non-Manhattan vias are not allowed.

Rule	Description	Lambda					
		5 Metal Process			6+ Metal Process		
		SCMOS	SUBM	DEEP	SCMOS	SUBM	DEEP
25.1	Exact size	n/a	2x2	3x3	n/a	2x2	3x3
25.2	Minimum spacing	n/a	3	3	n/a	3	3
25.3	Minimum overlap by Metal4	n/a	1	1	n/a	1	1

## SCMOS Layout Rules - Metal5 (SUBM and DEEP)

Any designer using the SCMOS rules who wants the TSMC Thick\_Top\_Metal must draw the top metal to comply with the TSMC rules for that layer.

Rule	Description	Lambda					
		5 Metal Process			6+ Metal Process		
		SCMOS	SUBM	DEEP	SCMOS	SUBM	DEEP
26.1	Minimum width	n/a	4	4	n/a	3	3
26.2	Minimum spacing to Metal5	n/a	4	4	n/a	3	4
26.3	Minimum overlap of Via4	n/a	1	2	n/a	1	1
26.4	Minimum spacing when either metal line is wider than 10 lambda	n/a	8	8	n/a	6	8

## SCMOS Layout Rules - Via5 (SUBM and DEEP)

Vias must be drawn orthogonal to the grid of the layout. Non-Manhattan vias are not allowed.

Rule	Description	Lambda		
		6 Metal Process		
		SCMOS	SUBM	DEEP
29.1	Exact size	n/a	3 x 3	4 x 4
29.2	Minimum spacing	n/a	4	4
29.3	Minimum overlap by Metal5	n/a	1	1

## SCMOS Layout Rules - Metal6 (SUBM and DEEP)

Any designer using the SCMOS rules who wants the TSMC Thick\_Top\_Metal must draw the top metal to comply with the TSMC rules for that layer.

Rule	Description	Lambda		
		6 Metal Process		
		SCMOS	SUBM	DEEP
30.1	Minimum width	n/a	5	5
30.2	Minimum spacing to Metal6	n/a	5	5
30.3	Minimum overlap of Via5	n/a	1	2
30.4	Minimum spacing when either metal line is wider than 10 lambda	n/a	10	10

## SCMOS Layout Rules - Overglass

Note that rules in this section are in units of microns, *not* lambda. They are not "true" design rules, but they do make good practice rules. Unfortunately, there are no really good generic pad design rules since pads are process-specific.

Rule	Description	Microns ( <i>not</i> lambda)
10.1	Minimum bonding passivation opening	60
10.2	Minimum probe passivation opening	20
10.3	Pad metal overlap of passivation	6
10.4	Minimum pad spacing to unrelated metal	30
10.5	Minimum pad spacing to active, poly or poly2	15

