

**ME222: Mechanics of Deformable Solids**

**Final Examination  
Summer 2004**

1. (4pts) Determine the reaction forces and moments at both ends of the bar shown below.

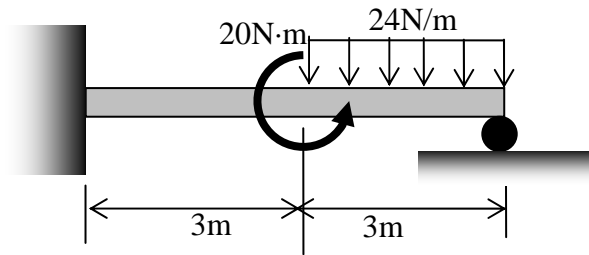

2. (4pts) Determine the stresses in aluminum and steel between A and B when they are loaded at C with 20kN of axial force. The elastic modulus of steel and aluminum are 200GPa and 70GPa, respectively.

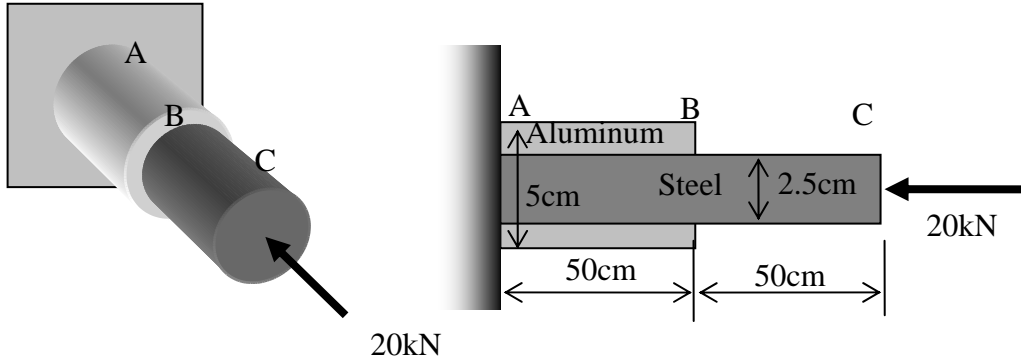

3. (4pts) The bar made of two materials, aluminum and steel, shown below is loaded with the torque of  $20\text{N}\cdot\text{m}$  at B. (a) Determine the maximum shear stresses in steel and aluminum. (b) Determine the angle of twist at B and C. The shear modulus of steel and aluminum are  $75\text{GPa}$  and  $25\text{GPa}$ , respectively.

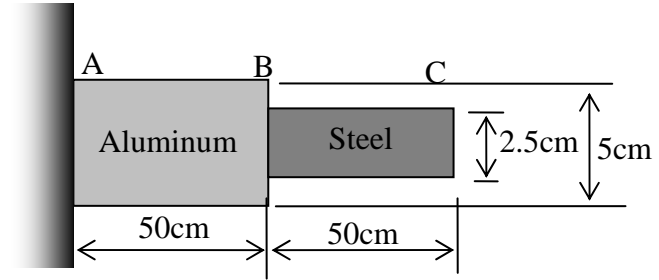
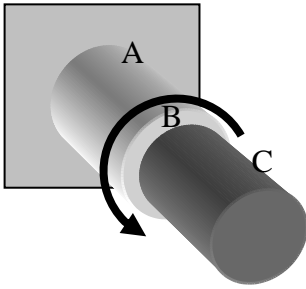

4. (4pts) Determine the stresses at A and B of the solid bar whose diameter at the base is 10cm.

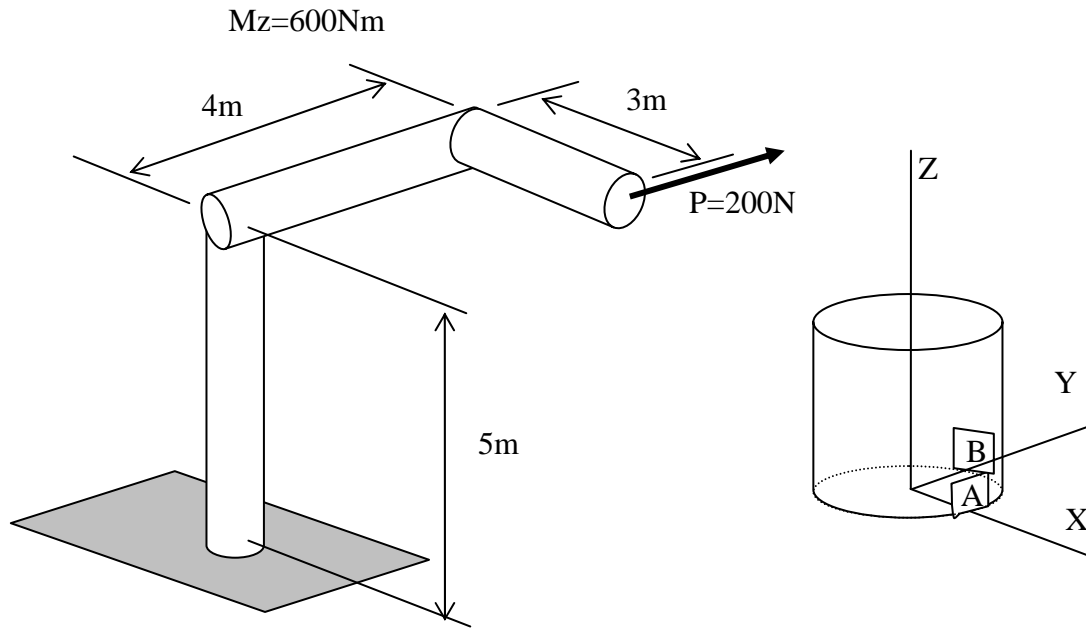

Name \_\_\_\_\_

5. (4pts) Determine the yield strength required from the material in order to withstand the pressure ( $P=1\text{MPa}$ ) and torsion ( $T=1\text{kNm}$ ) on the cylindrical pressure vessel. One bottom side of the vessel fastened to the base. The outer radius is  $15\text{cm}$  and the thickness is  $1\text{cm}$ .

