

## Supplemental Details on the MSU P-x-y Apparatus

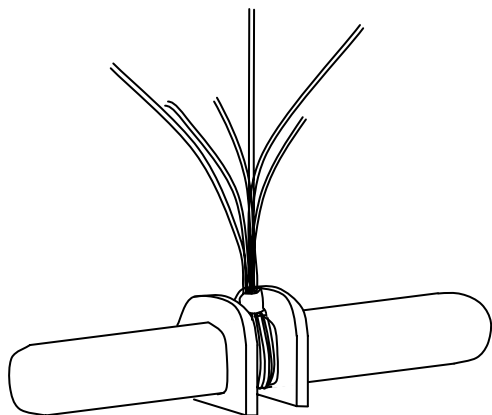

**Figure 1.** Illustration of the agitator used to provide stirring of vapor and liquid phases. The supports were cut from a thin sheet of Teflon. Thin polypropylene strips are used to agitate the vapor phase, and secured with a strip of Teflon plumbing tape.

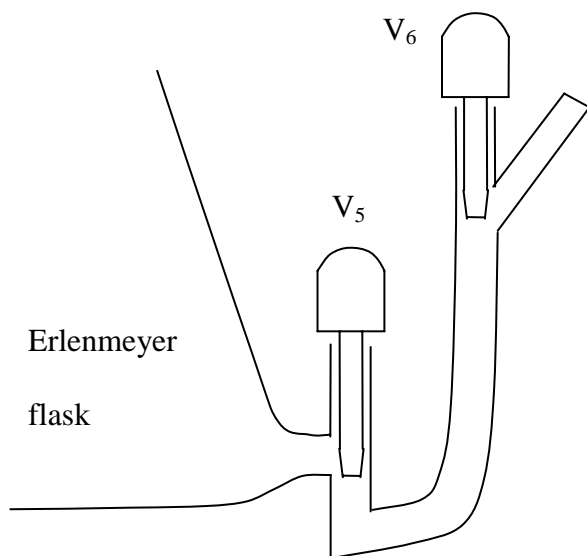

**Figure 2.** Schematic of the chamber, showing the configuration for the liquid sampling valves.

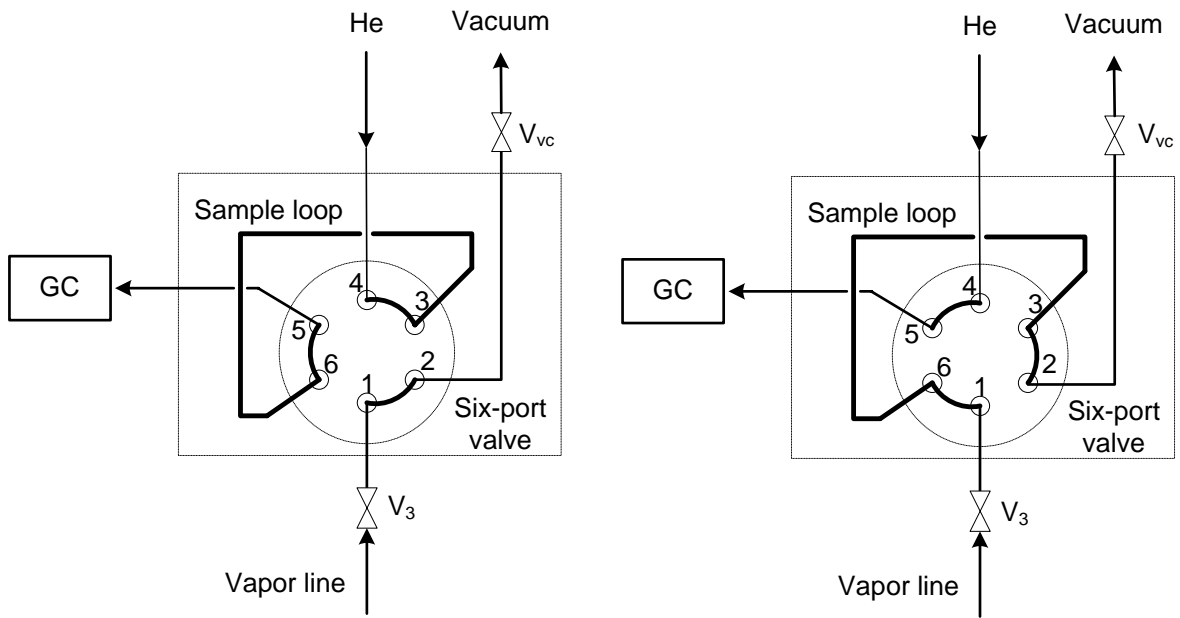

**Figure 3.** Schematic of the vapor sampling valve showing the inject (left) and load (right) positions.