

# **Nonlinear Systems and Control**

## **Lecture # 17**

### **Circle & Popov Criteria**

# Absolute Stability

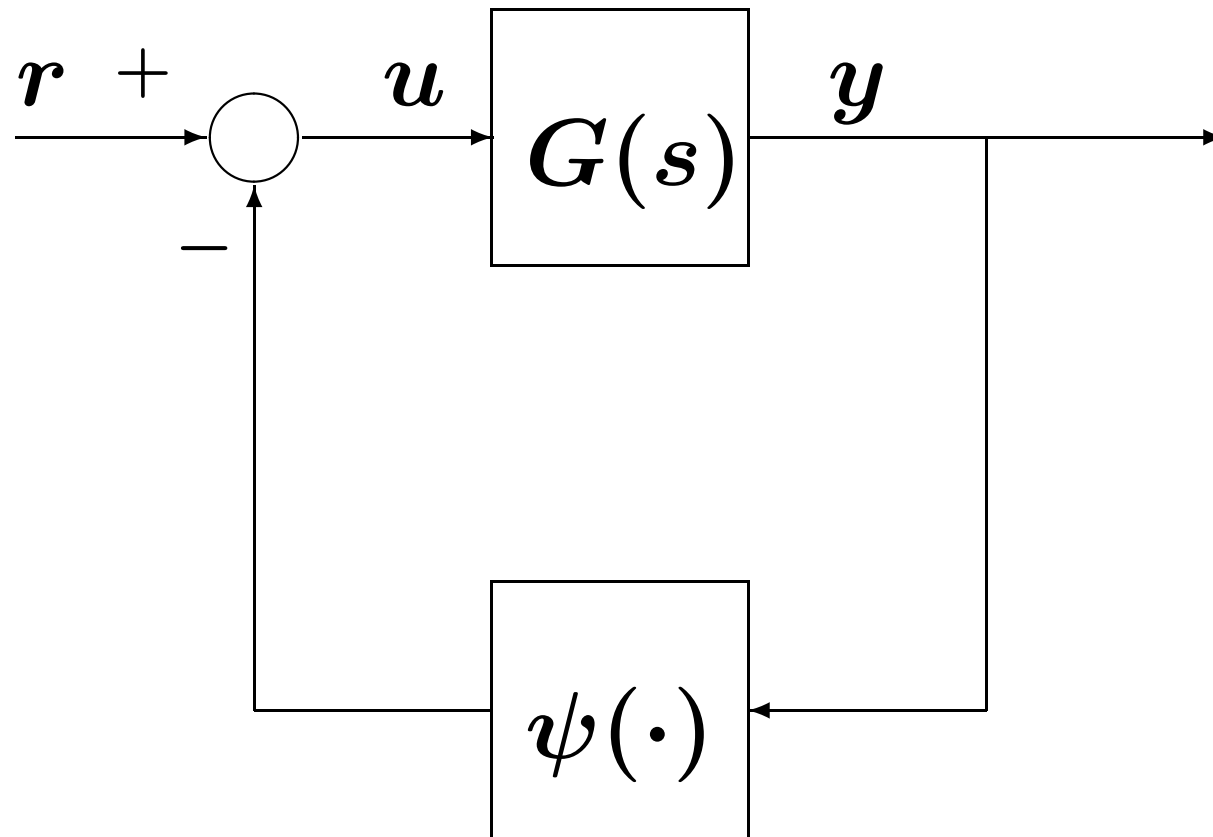

The system is absolutely stable if (when  $r = 0$ ) the origin is globally asymptotically stable for all memoryless time-invariant nonlinearities in a given sector

# Circle Criterion

Suppose  $G(s) = C(sI - A)^{-1}B + D$  is SPR and  $\psi \in [0, \infty]$

$$\dot{x} = Ax + Bu$$

$$y = Cx + Du$$

$$u = -\psi(y)$$

By the KYP Lemma,  $\exists P = P^T > 0, L, W, \varepsilon > 0$

$$PA + A^T P = -L^T L - \varepsilon P$$

$$PB = C^T - L^T W$$

$$W^T W = D + D^T$$

$$V(x) = \frac{1}{2}x^T P x$$

$$\begin{aligned}
\dot{V} &= \frac{1}{2}x^T P \dot{x} + \frac{1}{2}\dot{x}^T P x \\
&= \frac{1}{2}x^T (PA + A^T P)x + x^T P B u \\
&= -\frac{1}{2}x^T L^T L x - \frac{1}{2}\varepsilon x^T P x + x^T (C^T - L^T W)u \\
&= -\frac{1}{2}x^T L^T L x - \frac{1}{2}\varepsilon x^T P x + (Cx + Du)^T u \\
&\quad - u^T D u - x^T L^T W u
\end{aligned}$$

$$u^T D u = \frac{1}{2}u^T (D + D^T)u = \frac{1}{2}u^T W^T W u$$

$$\dot{V} = -\frac{1}{2}\varepsilon x^T P x - \frac{1}{2}(Lx + Wu)^T (Lx + Wu) - y^T \psi(y)$$

$$y^T \psi(y) \geq 0 \quad \Rightarrow \quad \dot{V} \leq -\frac{1}{2}\varepsilon x^T P x$$

The origin is globally exponentially stable

What if  $\psi \in [K_1, \infty]$ ?

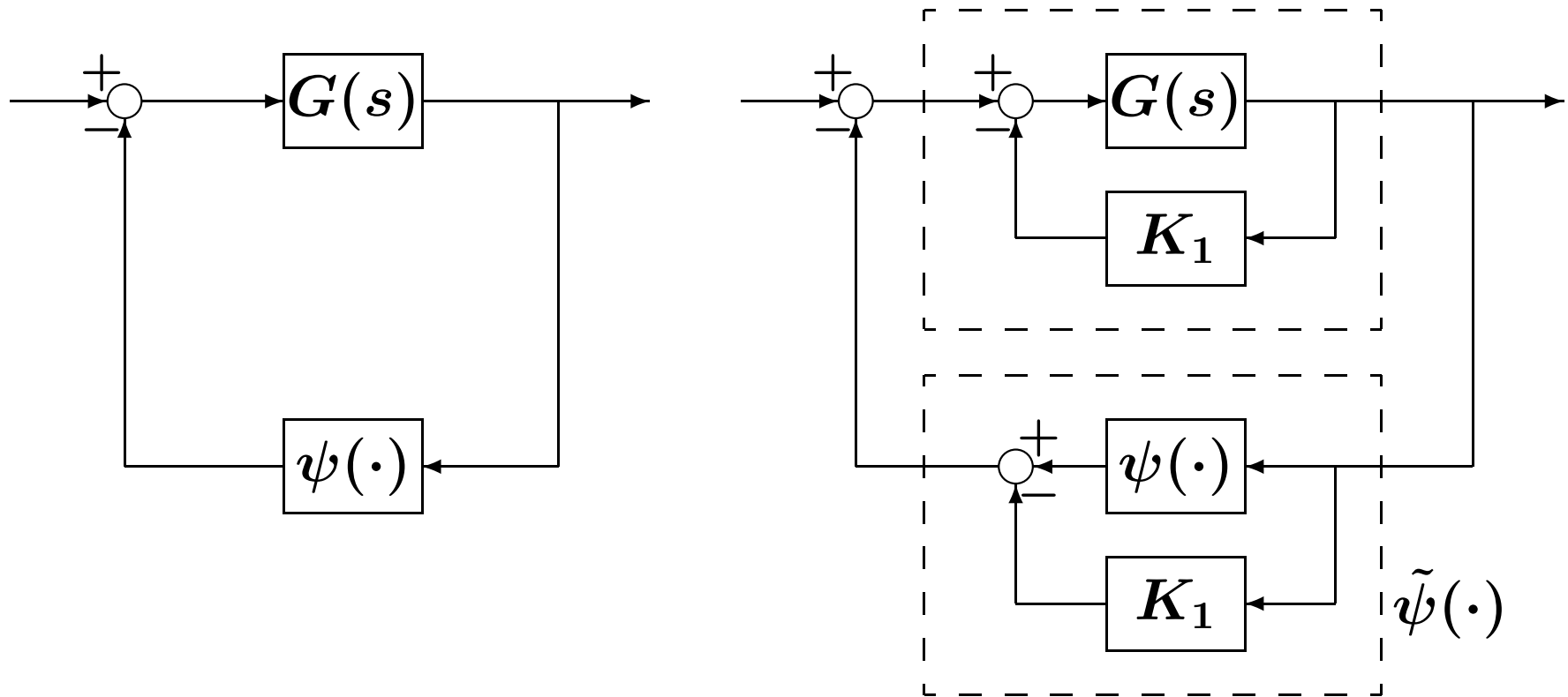

$\tilde{\psi} \in [0, \infty]$ ; hence the origin is globally exponentially stable if  $G(s)[I + K_1 G(s)]^{-1}$  is SPR

What if  $\psi \in [K_1, K_2]$ ?

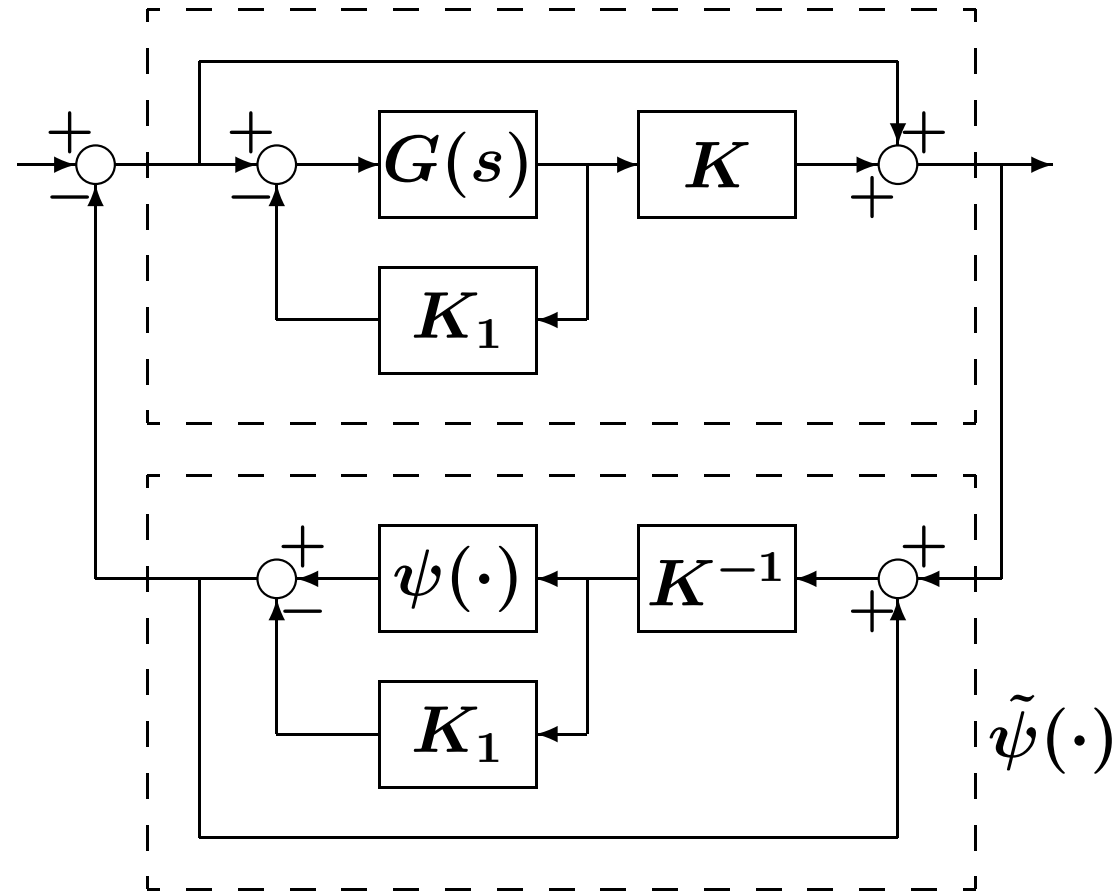
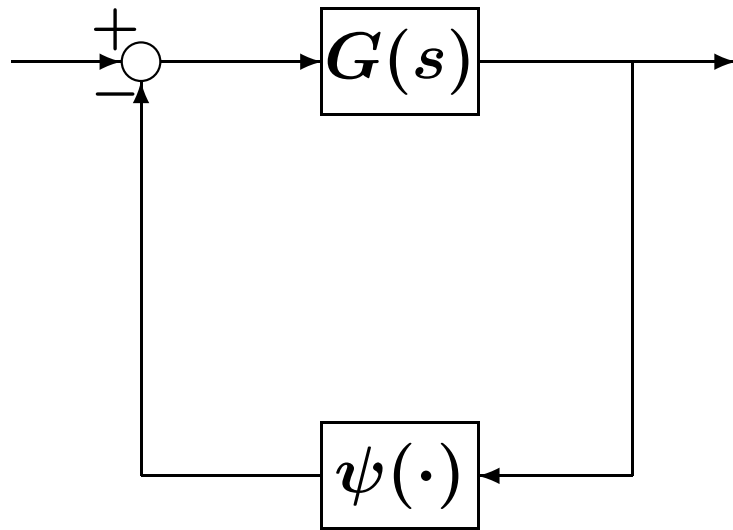

$\tilde{\psi} \in [0, \infty]$ ; hence the origin is globally exponentially stable if  $I + KG(s)[I + K_1G(s)]^{-1}$  is SPR

$$I + KG(s)[I + K_1G(s)]^{-1} = [I + K_2G(s)][I + K_1G(s)]^{-1}$$

**Theorem (Circle Criterion):** The system is absolutely stable if

- $\psi \in [K_1, \infty]$  and  $G(s)[I + K_1G(s)]^{-1}$  is SPR, or
- $\psi \in [K_1, K_2]$  and  $[I + K_2G(s)][I + K_1G(s)]^{-1}$  is SPR

**Scalar Case:**  $\psi \in [\alpha, \beta]$ ,  $\beta > \alpha$

The system is absolutely stable if

$$\frac{1 + \beta G(s)}{1 + \alpha G(s)} \text{ is Hurwitz and}$$

$$\operatorname{Re} \left[ \frac{1 + \beta G(j\omega)}{1 + \alpha G(j\omega)} \right] > 0, \quad \forall \omega \in [0, \infty]$$

Case 1:  $\alpha > 0$

By the Nyquist criterion

$$\frac{1 + \beta G(s)}{1 + \alpha G(s)} = \frac{1}{1 + \alpha G(s)} + \frac{\beta G(s)}{1 + \alpha G(s)}$$

is Hurwitz if the Nyquist plot of  $G(j\omega)$  does not intersect the point  $-(1/\alpha) + j0$  and encircles it  $m$  times in the counterclockwise direction, where  $m$  is the number of poles of  $G(s)$  in the open right-half complex plane

$$\frac{1 + \beta G(j\omega)}{1 + \alpha G(j\omega)} = \frac{\frac{1}{\beta} + G(j\omega)}{\frac{1}{\alpha} + G(j\omega)}$$

$$\operatorname{Re} \left[ \frac{\frac{1}{\beta} + G(j\omega)}{\frac{1}{\alpha} + G(j\omega)} \right] > 0, \quad \forall \omega \in [0, \infty]$$

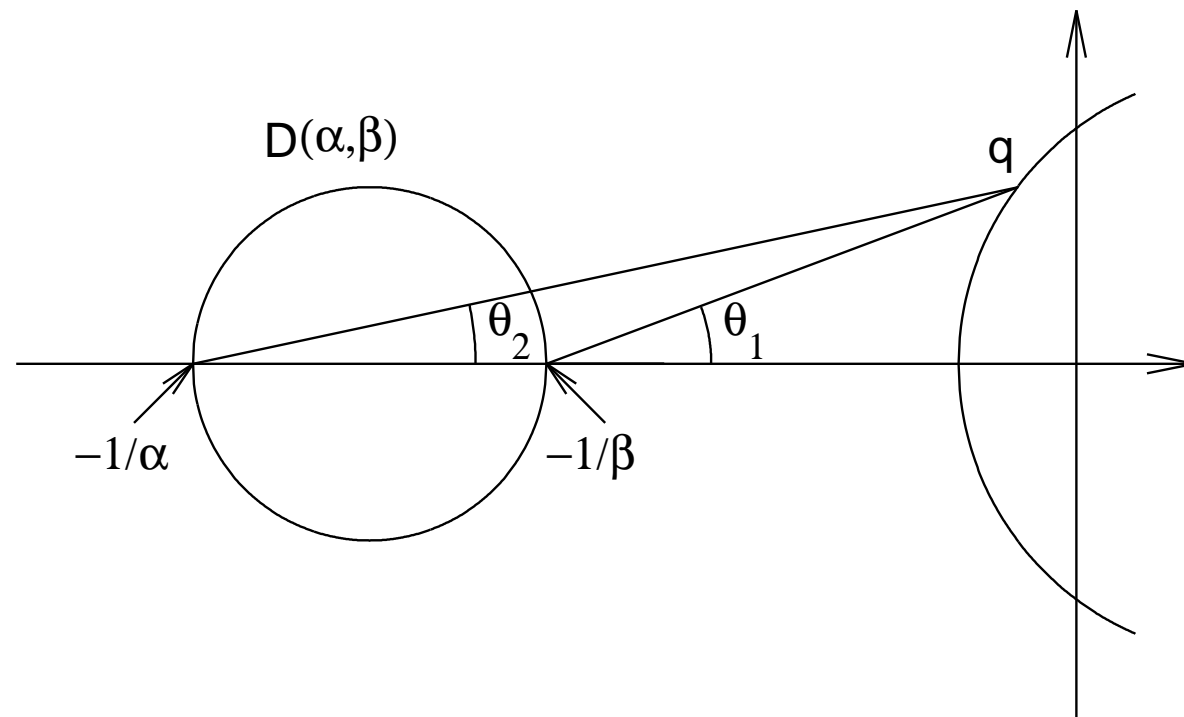

The system is absolutely stable if the Nyquist plot of  $G(j\omega)$  does not enter the disk  $D(\alpha, \beta)$  and encircles it  $m$  times in the counterclockwise direction

Case 2:  $\alpha = 0$

$$1 + \beta G(s)$$

$$\operatorname{Re}[1 + \beta G(j\omega)] > 0, \quad \forall \omega \in [0, \infty]$$

$$\operatorname{Re}[G(j\omega)] > -\frac{1}{\beta}, \quad \forall \omega \in [0, \infty]$$

The system is absolutely stable if  $G(s)$  is Hurwitz and the Nyquist plot of  $G(j\omega)$  lies to the right of the vertical line defined by  $\operatorname{Re}[s] = -1/\beta$

Case 3:  $\alpha < 0 < \beta$

$$\operatorname{Re} \left[ \frac{1 + \beta G(j\omega)}{1 + \alpha G(j\omega)} \right] > 0 \Leftrightarrow \operatorname{Re} \left[ \frac{\frac{1}{\beta} + G(j\omega)}{\frac{1}{\alpha} + G(j\omega)} \right] < 0$$

The Nyquist plot of  $G(j\omega)$  must lie inside the disk  $D(\alpha, \beta)$ .  
The Nyquist plot cannot encircle the point  $-(1/\alpha) + j0$ .  
From the Nyquist criterion,  $G(s)$  must be Hurwitz

The system is absolutely stable if  $G(s)$  is Hurwitz and the Nyquist plot of  $G(j\omega)$  lies in the interior of the disk  $D(\alpha, \beta)$

## Example

$$G(s) = \frac{4}{(s + 1)\left(\frac{1}{2}s + 1\right)\left(\frac{1}{3}s + 1\right)}$$

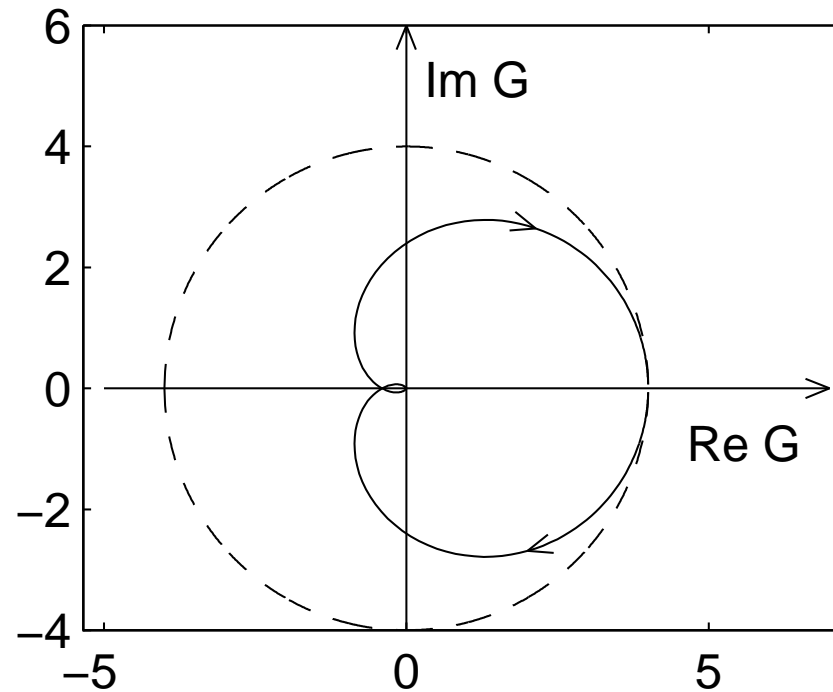

Apply Case 3 with center  $(0, 0)$  and radius = 4

Sector is  $(-0.25, 0.25)$

Apply Case 3 with center  $(1.5, 0)$  and radius = 2.834

Sector is  $[-0.227, 0.714]$

Apply Case 2

The Nyquist plot is to the right of  $\text{Re}[s] = -0.857$

Sector is  $[0, 1.166]$

$[0, 1.166]$  includes the saturation nonlinearity

## Example

$$G(s) = \frac{4}{(s - 1)\left(\frac{1}{2}s + 1\right)\left(\frac{1}{3}s + 1\right)}$$

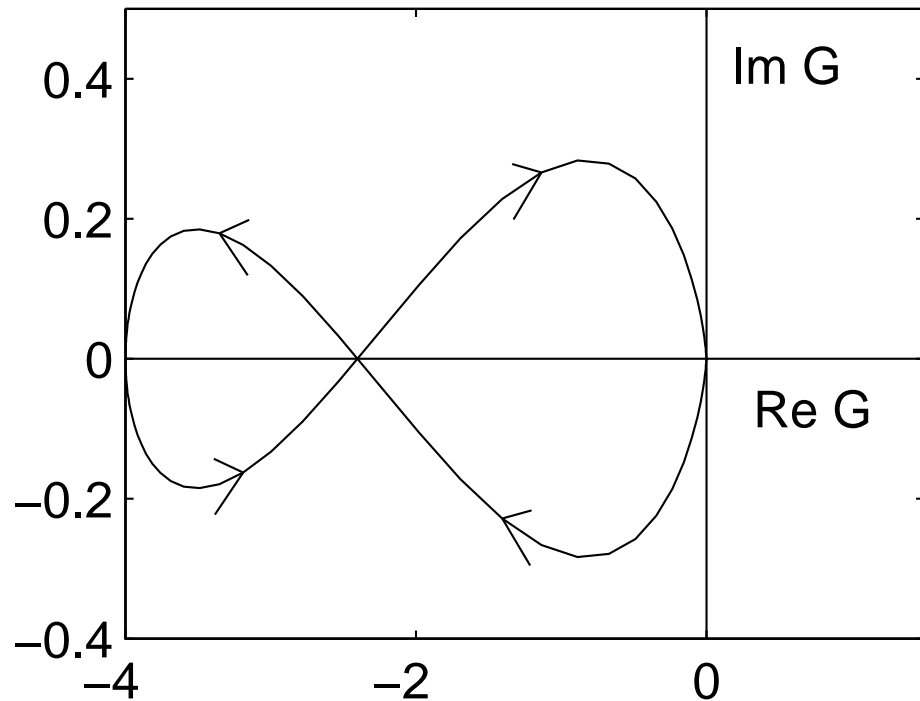

$G$  is not Hurwitz

Apply Case 1

Center =  $(-3.2, 0)$ , Radius =  $0.168 \Rightarrow [0.2969, 0.3298]$

# Popov Criterion

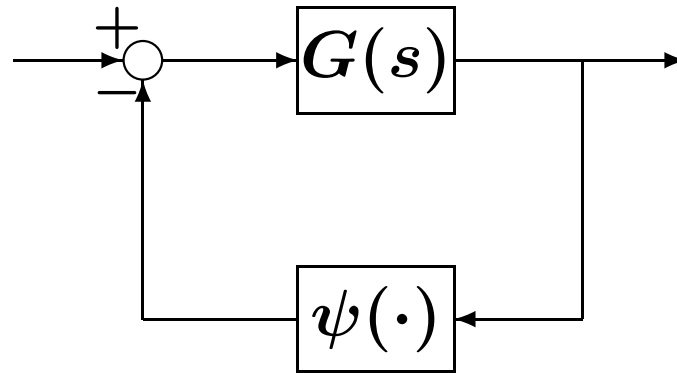

$$\dot{x} = Ax + Bu$$

$$y = Cx$$

$$u_i = -\psi_i(y_i), \quad 1 \leq i \leq p$$

$$\psi_i \in [0, k_i], \quad 1 \leq i \leq p, \quad (0 < k_i \leq \infty)$$

$$G(s) = C(sI - A)^{-1}B$$

$$\Gamma = \text{diag}(\gamma_1, \dots, \gamma_p), \quad M = \text{diag}(1/k_1, \dots, 1/k_p)$$

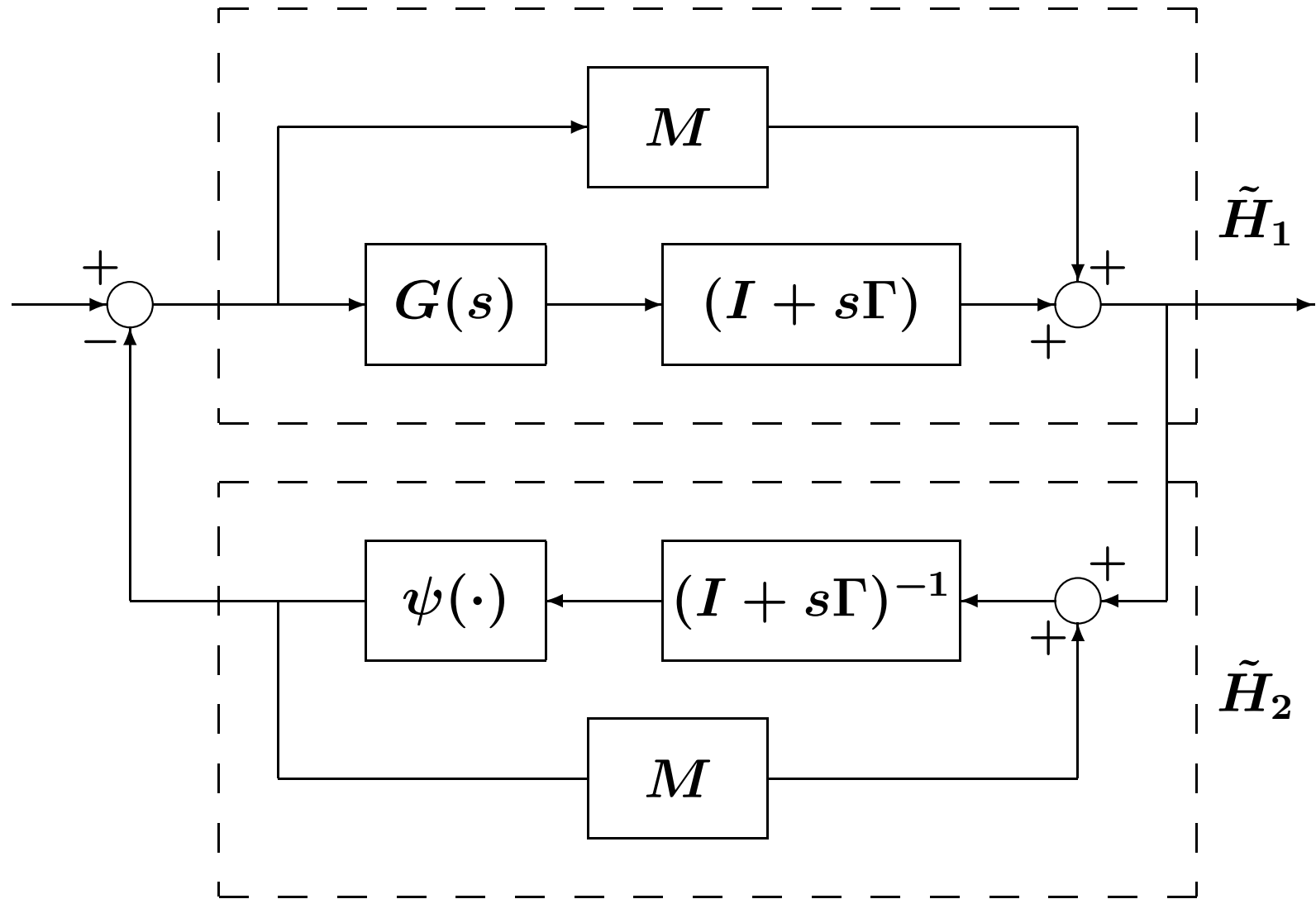

Show that  $\tilde{H}_1$  and  $\tilde{H}_2$  are passive

$$\begin{aligned}
& M + (I + s\Gamma)G(s) \\
&= M + (I + s\Gamma)C(sI - A)^{-1}B \\
&= M + C(sI - A)^{-1}B + \Gamma C s(sI - A)^{-1}B \\
&= M + C(sI - A)^{-1}B + \Gamma C(sI - A + A)(sI - A)^{-1}B \\
&= (C + \Gamma CA)(sI - A)^{-1}B + M + \Gamma CB
\end{aligned}$$

If  $M + (I + s\Gamma)G(s)$  is SPR, then  $\tilde{H}_1$  is strictly passive with the storage function  $V_1 = \frac{1}{2}x^T P x$ , where  $P$  is given by the KYP equations

$$\begin{aligned}
PA + A^T P &= -L^T L - \varepsilon P \\
PB &= (C + \Gamma CA)^T - L^T W \\
W^T W &= 2M + \Gamma CB + B^T C^T \Gamma
\end{aligned}$$

$\tilde{H}_2$  consists of  $p$  decoupled components:

$$\gamma_i \dot{z}_i = -z_i + \frac{1}{k_i} \psi_i(z_i) + \tilde{e}_{2i}, \quad \tilde{y}_{2i} = \psi_i(z_i)$$

$$V_{2i} = \gamma_i \int_0^{z_i} \psi_i(\sigma) d\sigma$$

$$\begin{aligned} \dot{V}_{2i} &= \gamma_i \psi_i(z_i) \dot{z}_i = \psi_i(z_i) \left[ -z_i + \frac{1}{k_i} \psi_i(z_i) + \tilde{e}_{2i} \right] \\ &= y_{2i} e_{2i} + \frac{1}{k_i} \psi_i(z_i) [\psi_i(z_i) - k_i z_i] \end{aligned}$$

$$\psi_i \in [0, k_i] \Rightarrow \psi_i(\psi_i - k_i z_i) \geq 0 \Rightarrow \dot{V}_{2i} \leq y_{2i} e_{2i}$$

$\tilde{H}_2$  is passive with the storage function

$$V_2 = \sum_{i=1}^p \gamma_i \int_0^{z_i} \psi_i(\sigma) d\sigma$$

Use 
$$V = \frac{1}{2}x^T P x + \sum_{i=1}^p \gamma_i \int_0^{y_i} \psi_i(\sigma) d\sigma$$

as a Lyapunov function candidate for the original feedback connection

$$\dot{x} = Ax + Bu, \quad y = Cx, \quad u = -\psi(y)$$

$$\begin{aligned} \dot{V} &= \frac{1}{2}x^T P \dot{x} + \frac{1}{2}\dot{x}^T P x + \psi^T(y) \Gamma \dot{y} \\ &= \frac{1}{2}x^T (PA + A^T P)x + x^T P B u \\ &\quad + \psi^T(y) \Gamma C (Ax + Bu) \\ &= -\frac{1}{2}x^T L^T L x - \frac{1}{2}\varepsilon x^T P x \\ &\quad + x^T (C^T + A^T C^T \Gamma - L^T W) u \\ &\quad + \psi^T(y) \Gamma C A x + \psi^T(y) \Gamma C B u \end{aligned}$$

$$\begin{aligned}
\dot{V} &= -\frac{1}{2}\varepsilon x^T P x - \frac{1}{2}(Lx + Wu)^T (Lx + Wu) \\
&\quad - \psi(y)^T [y - M\psi(y)] \\
&\leq -\frac{1}{2}\varepsilon x^T P x - \psi(y)^T [y - M\psi(y)]
\end{aligned}$$

$$\psi_i \in [0, k_i] \Rightarrow \psi(y)^T [y - M\psi(y)] \geq 0 \Rightarrow \dot{V} \leq -\frac{1}{2}\varepsilon x^T P x$$

The origin is globally asymptotically stable

**Popov Criterion:** The system is absolutely stable if, for  $1 \leq i \leq p$ ,  $\psi_i \in [0, k_i]$  and there exists a constant  $\gamma_i \geq 0$ , with  $(1 + \lambda_k \gamma_i) \neq 0$  for every eigenvalue  $\lambda_k$  of  $A$ , such that  $M + (I + s\Gamma)G(s)$  is strictly positive real

## Scalar case

$$\frac{1}{k} + (1 + s\gamma)G(s)$$

is SPR if  $G(s)$  is Hurwitz and

$$\frac{1}{k} + \operatorname{Re}[G(j\omega)] - \gamma\omega \operatorname{Im}[G(j\omega)] > 0, \quad \forall \omega \in [0, \infty)$$

If

$$\lim_{\omega \rightarrow \infty} \left\{ \frac{1}{k} + \operatorname{Re}[G(j\omega)] - \gamma\omega \operatorname{Im}[G(j\omega)] \right\} = 0$$

we also need

$$\lim_{\omega \rightarrow \infty} \omega^2 \left\{ \frac{1}{k} + \operatorname{Re}[G(j\omega)] - \gamma\omega \operatorname{Im}[G(j\omega)] \right\} > 0$$

$$\frac{1}{k} + \operatorname{Re}[G(j\omega)] - \gamma\omega \operatorname{Im}[G(j\omega)] > 0, \quad \forall \omega \in [0, \infty)$$

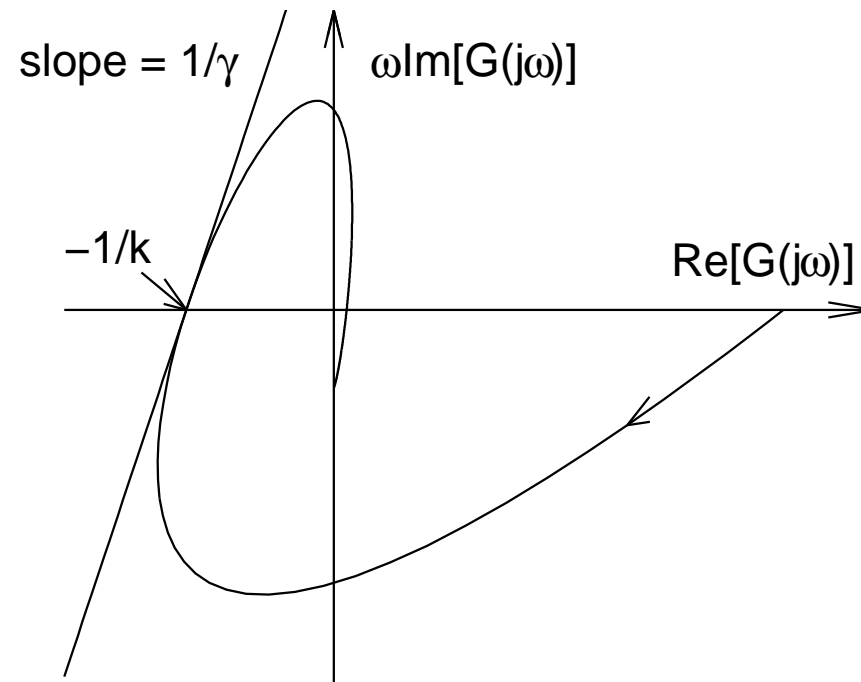

Popov Plot

## Example

$$\dot{x}_1 = x_2, \quad \dot{x}_2 = -x_2 - h(y), \quad y = x_1$$

$$\dot{x}_2 = -\alpha x_1 - x_2 - h(y) + \alpha x_1, \quad \alpha > 0$$

$$G(s) = \frac{1}{s^2 + s + \alpha}, \quad \psi(y) = h(y) - \alpha y$$

$$h \in [\alpha, \beta] \Rightarrow \psi \in [0, k] \quad (k = \beta - \alpha > 0)$$

$$\gamma > 1 \Rightarrow \frac{\alpha - \omega^2 + \gamma\omega^2}{(\alpha - \omega^2)^2 + \omega^2} > 0, \quad \forall \omega \in [0, \infty)$$

$$\text{and } \lim_{\omega \rightarrow \infty} \frac{\omega^2(\alpha - \omega^2 + \gamma\omega^2)}{(\alpha - \omega^2)^2 + \omega^2} = \gamma - 1 > 0$$

The system is absolutely stable for  $\psi \in [0, \infty]$  ( $h \in [\alpha, \infty]$ )

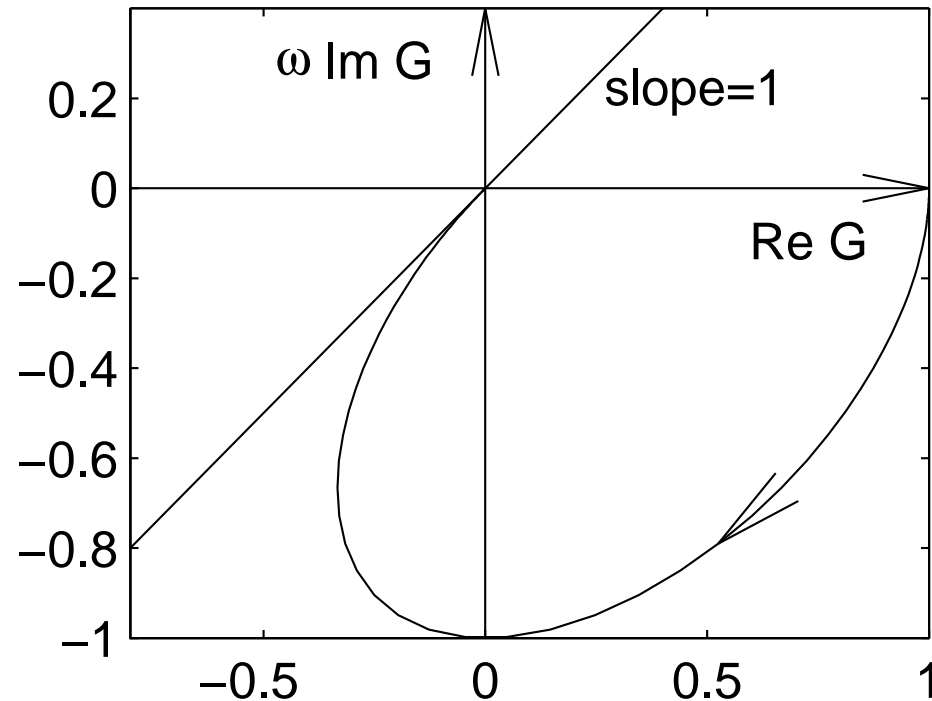

Compare with the circle criterion ( $\gamma = 0$ )

$$\frac{1}{k} + \frac{\alpha - \omega^2}{(\alpha - \omega^2)^2 + \omega^2} > 0, \quad \forall \omega \in [0, \infty], \quad \text{for } k < 1 + 2\sqrt{\alpha}$$