

QUARTZ CRYSTAL MICROBALANCE STUDY OF DNA IMMOBILIZATION AND HYBRIDIZATION FOR DNA SENSOR DEVELOPMENT

by

Biao Chang & Tan Zhao

Department of Civil and Environmental Engineering

Michigan State University

Apr 2008



MICHIGAN STATE UNIVERSITY
Civil and Environmental Engineering

Table of Contents

Abstract	1
1. Mechanistic Theories for QCM	2
1.1 Quartz Crystal Microbalance Background	2
1.2 Theories for Mass Measurement of QCM	3
1.3 QCM as Biosensors.....	5
2. Equipment Design.....	8
2.1 Lab Setup	8
2.2 Flow Cell Design	10
3. Experimental Protocols for QCM DNA Biosensor	12
4. Work in the Future	13
Acknowledgement	14
References.....	15
Appendix: Experimental Reagents	17

Abstract

Piezoelectric materials such as quartz can be used to detect mass change due to their piezoelectric properties. Quartz Crystal Microbalance (QCM) is an extremely sensitive mass sensor, capable of measuring sub-nanogram levels by detecting change in the frequency of a quartz crystal resonator, which makes it a promising candidate for biosensor applications. In this project, the mechanistic theories related to QCM mass measurement was reviewed and summarized. Based on the theories, a lab-scale QCM mass measurement unit was set up. Fundamental theories and experimental techniques for QCM DNA detection were investigated, and a protocol for the construction of QCM DNA biosensor was developed. The potential for QCM to be employed as immunosensor was also discussed.

1. Mechanistic Theories for QCM

1.1 Quartz Crystal Microbalance Background

Piezoelectric materials such as quartz can be used to detect mass change due to their piezoelectric property. Quartz Crystal when properly cut and applied a certain A/C pressure will have an oscillation at certain frequency. This frequency is very sensitive to the mass of the crystal (Spetz, 2006). Quartz Crystal Microbalance is an electro acoustic method suitable for mass and viscoelastic analysis of adsorbed layers at the solid/water or solid/air interface. It measures a mass per unit area by measuring the change in frequency of a quartz crystal resonator.

A typical QCM sensor consists of a megahertz piezoelectric quartz crystal sandwiched between two gold electrodes. The crystal can be brought to resonant oscillation, and shear motions by means of A/C current between the electrodes. Since the resonant frequency (f) can be determined with very high precision, usually less than 1 Hz, the adsorbed mass at the QCM-surface can be detected down to a few ng/cm². For different applications, various categories of target absorbing layers will be coated on the crystal surface. Targets absorbing on the surface will change the mass of the crystal and hence the frequency of the acoustic wave. (Spetz, 2006)

There is also another special QCM called QCM-D. The instrumentation for making pulse assisted discrimination of f and D is called QCM-D and is made by Q-Sense AB. The Dissipation factor gives information about the structure of the adhering/attached layer oscillating with the sensor crystal. In liquid, an adsorbed film may consist of a considerably high amount of water, which is sensed as a mass uptake by all QCMs. The structural flexibility or viscoelasticity are invisible at simple f determination.

Viscoelasticity can, however, be visualised by measuring the energy loss, or dissipation (D) of the shear movement of the crystal in water. A new principle of measuring D is to drive the crystal with A/C current at the resonant f followed by disconnection and analysis of the resulting damped sinusoidal curve. This new invention of pulse assisted discrimination of f and D makes QCM analysis of adsorbed protein layers very simple

and gives unique information about the hydrodynamic conductivity of the adsorbed protein layers and surrounding water. Very small structural and orientation changes of an adsorbed protein layer, including chemical cross-linking, will be monitored with high accuracy. By collecting both the dissipation and the resonance frequency of a quartz crystal, QCM-D technology can be used to characterize the formation of thin films (nm) such as proteins, polymers and cells onto surfaces, in liquid. By measuring several frequencies and the dissipation it becomes possible to determine whether the adsorbed film is rigid or water-rich (soft).

1.2 Theories for Mass Measurement of QCM

1.2.1 QCM for gas-phase measurements:

The quartz crystal microbalance (QCM) as a piezoelectric sensor is based on the measurement of mass changes on the surface of a piezoelectric crystal caused by the specific adsorption of target molecules. Performance of the crystal is quantitatively characterized by the Sauerbrey equation, named after the pioneer of this technique for measurement of film thickness.

The Sauerbrey equation:

$$\Delta f = -\frac{2f_0^2}{A\sqrt{\mu_q\rho_q}}\Delta m$$

where Δf is frequency change of the quartz crystal, f_0 is the fundamental resonant frequency of the crystal, Δm is the mass change; A is the active vibrating area (usually the electrode area), μ_q is the shear modulus of the quartz, and ρ_q is the density of the quartz.

According to Sauerbrey equation, correlation between frequency and mass change of the QCM is linear, $\Delta f = -s\Delta m$. This equation permits determination of quantitative mass changes of the quartz by measuring frequency changes.

Sauerbrey law holds for gas-phase measurements and is applicable only when the mass increase is not too important, and the adsorbed material is rigidly attached to the crystal

surface and of negligible thickness in comparison to the crystal itself (Caruso, 1995; Lazerges, 2006). Nevertheless, for DNA detection, even if there is a viscoelastic energy dissipation, it has been found that it is possible to correlate linearly relative frequency and mass changes for DNA strands below 450 bases (Lazerges, 2006).

1.2.2 QCM for liquid-phase measurements:

For many cases of QCM applied in contact with liquids, the Sauerbrey equation does not hold. A number of factors such as interfacial liquid properties (i.e., density, viscosity, conductivity, and dielectric constant), thin film viscoelasticity, electrode morphology, and mechanisms of acoustic coupling impact on QCM oscillation behavior (Caruso, 1995). It was thought that the viscous damping would cause large frequency shifts and large losses in the quality factor Q leading to instability and even cessation of oscillation (Kanazawa, 1985). Actually, operation of QCM in liquids is possible. A most commonly used model to predict the change in resonance frequency which accompanies immersion of the quartz into a viscous medium is developed by Kanazawa and Gordon (Kanazawa, 1985) as below:

$$\Delta f = f_0^{3/2} \left(\frac{\eta_L \rho_L}{\pi \mu_q \rho_q} \right)^{1/2}$$

where Δf is the decrease in unloaded crystal's oscillation frequency f_0 , η_L is viscosity of the liquid in contact with the electrode, ρ_L is density of the liquid in contact with the electrode, μ_q is the shear modulus of the quartz, and ρ_q is the density of the quartz.

Despite the equation above, the QCM operation in liquids remains poorly understood, and many experimental results for QCM frequency changes in liquids deviate from theoretical predictions (Caruso, 1995).

In practice of research, the quartz crystal is usually designed to contact with liquids at one side only ("one-side cell") (Caruso, 1997; Zhou, 2001; Towery, 2004; Mannelli, 2005; Zhu, 2005; Takahashi, 2007). The reason for this is to eliminate the influences of conductivity and dielectric constant, as well as to reduce the liquid damping. A special

casing for the quartz plate is required to prevent liquid contact on the other side of the quartz, which is commonly realized by a rubber or Teflon seal or gluing technology (Auge, 1995). By one-side contact with liquid, the crystal can usually reach a stable oscillation condition.

For the totally immersed quartz disc, it is usually difficult to obtain a stable frequency. While Auge et al. (Auge, 1995) indicated that this totally immersed quartz disc can be done in non-conductive liquids with a low dielectric constant, such as hydrocarbons, we have found few literatures on successful use of totally immersed quartz crystal. In our experiment, the quartz crystal also failed to reach a stable oscillation state in deionized water.

1.3 QCM as Biosensors

Since QCM is an extremely sensitive mass sensor, capable of measuring sub-nanogram levels, it is a promising candidate for biosensor applications.

1.3.1 QCM DNA Sensors:

QCM DNA-biosensors are time resolved, sensitive enough to detect non-labelled DNA, selective enough to detect single mismatch DNA, and allow multi-analysis (Lazerges, 2006). The basis for operation of a QCM DNA-biosensor is the complementary coupling between the specific DNA sequences within target analytes and the specific DNA sequences immobilized onto the solid surface of the piezoelectric transducer QCM. Among other types of DNA biosensors, QCM has the advantages of a solid-state construction, chemical inertness, durability, and ultimately the possibility of low cost mass production (Zhou, 2001).

DNA probe immobilization:

The immobilization of specific DNA sequences (oligonucleotide probes) on the QCM surface can be realized by a wide range of techniques: chemical adsorption of a DNA labeled with a disulfide or thiol group on the gold electrodes; covalent binding of a DNA labeled with amine on a surface modified with a silane derivative; peptide bounding of a DNA labeled with amine on a quartz surface chemically modified with ethylenediamine;

formation of a biotin-avidin complex between a DNA labeled with biotin and an avidin modified surface (i.e. copolymer pyrrole-avidin film, dextran-avidin layer, or thiol-avidin layer), and DNA photografting to polystyrene (Lazerges, 2006).

Zhou et al. (Zhou, 2001) compared different methods for immobilization of DNA probe on QCM electrodes by chemical bonding or electrostatic adsorption to form monolayer or multilayer DNA sensing films. The six coatings summarized in Fig. 1 are: (a) Biotin-DNA immobilized via interaction with avidin which is covalently bonded on the QCM electrode; (b) Biotin-DNA immobilized via interaction with avidin which is adsorbed on (PAAH/PSS) precursor film by electrostatic adsorption to form monolayer sensing film; (c) Biotin-DNA immobilized with avidin/PSS multilayer films constructed by alternate deposition of avidin and PSS on (PAAH/PSS) precursor film coated QCM electrodes; (d) DNA probe immobilized on the outer layer of PAH/PSS/PAH film as monolayer by electrostatic adsorption; (e) DNA probe immobilized on the outer layer of PAH/PSS/PAH film as multilayer sensing film by alternate deposition of avidin and PSS; (f) DNA probe immobilized directly on QCM electrode by chemical bonding.

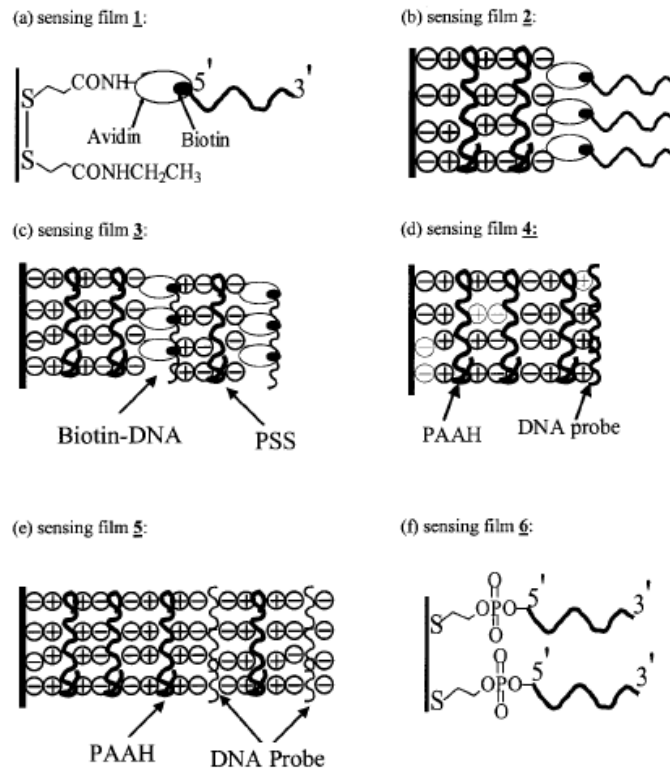

Fig. 1 Commonly Used DNA Immobilization Techniques (Zhou, 2001)

Based on the experimental results (Zhou, 2001), Sensing Film 1 in Fig. 1 has high sensitivity and yet its fabrication procedure is relatively simple. Besides, since the biotin-avidin affinity is quite strong, and the layer is relatively thin, Sensing Film 1 is also mechanically stable. As a result, it is chosen as the coating method for our experiment.

Regeneration of DNA probe (dehybridization):

After a whole process of DNA detection has been completed, if to reuse the QCM biosensor, the coating needs to be refreshed so that new DNA probes are available to couple with target DNA sequences. The approaches for regeneration of DNA probes could be divided into two main categories: (1) reconstruction of the sensing film; (2) denaturation of the DNA duplex (dehybridization). The latter is adopted in our experiment, since it is more cost effective and simpler to realize.

In previous studies, DNA duplex dehybridization methods used for QCM DNA sensors include: (1) DNA probe regeneration by two consecutive treatments of 30s with 1 mM HCl (Mannelli, 2005); (2) DNA probe dehybridization by 0.5M NaOH (with 3M NaCl) circulation for 20 min (Lazerges, 2006); (3) DNA probe regeneration by incubation of the hybridized sensor in 0.1M NaOH for 10 s at room temperature followed by thorough water rinsing (Dupont-Filliard, 2004).

Since the immobilization method and DNA probe used by Mannelli et al. (Mannelli, 2005) are more similar with those in our experiment, method (1) in the previous paragraph, which was used by Mannelli et al. (Mannelli, 2005), is selected as our dehybridization method.

1.3.2 QCM Immunosensors:

QCM is also widely used as immunosensor for virus detection (Eun, 2002; Lee & Chang, 2005; Su, 2003; Susmel, 2000; Uttenthaler, 2001). Immunosensors transduce antigen-antibody interactions directly into frequency change of QCM. The design and preparation of an optimum interface between the biocomponents and the detector material is the key part of sensor development. Almost all of the reports coated the gold crystals surface by virus-specific antibody, although the antibody immobilization methods are different from each other. Methods for antibody immobilization including passive adsorption,

protein, amino acid, sulphide and thiols self-assembled layer (Lee et al., 2005; Susmel et al., 2000). The increase in mass on the QCM surface on binding of the virions results in reduction of frequency of resonance oscillation (Eun et al., 2002). Performance of QCM-based sensor with the conventional enzyme-linked immunosorbent assay (ELISA) method was compared. The result showed that sensitivity of QCM was comparable or even greater than ELISA method and QCM assay was much faster (Eun et al., 2002; Su et al., 2003). The measurement could be obtained directly, within several minutes, rather than hours as required visualizing the results of ELISA (Lee et al., 2005).

2. Equipment Design

2.1 Lab Setup

A typical Quartz Crystal Microbalance system is consisted by quartz crystal, oscillator, frequency counter and a computer. These items will be connected into a working circle as show in the following figure.

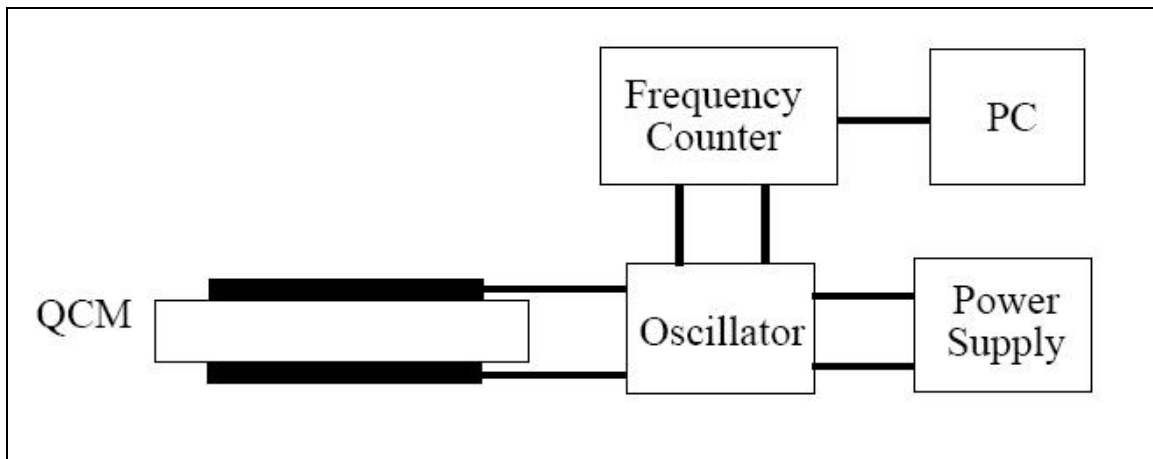

Fig. 2 Schematic Representation of the Mass Measurement Circuit

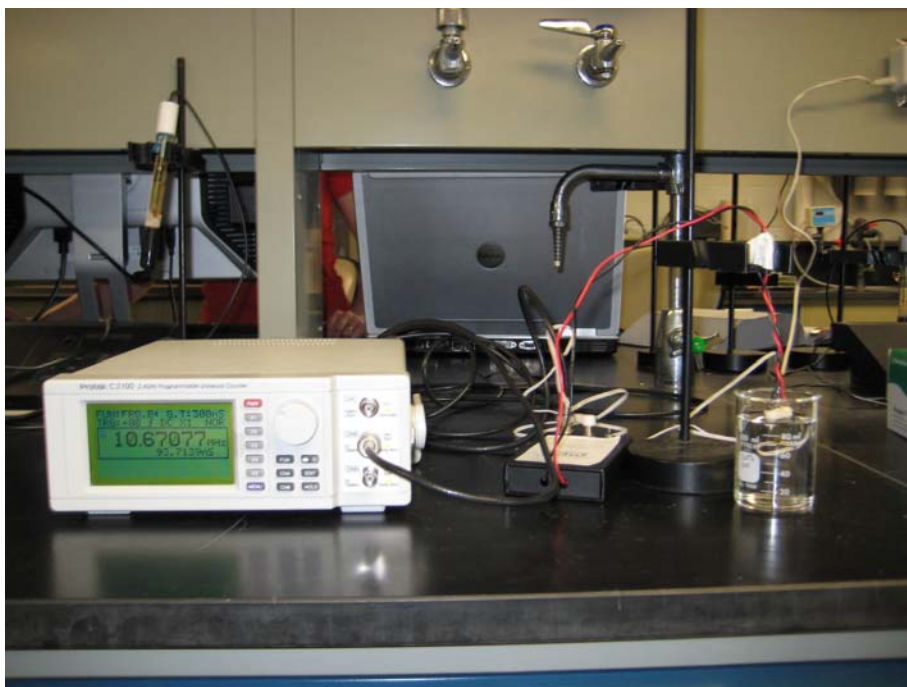

Fig. 3 Lab Setup of Quartz Crystal Microbalance

The quartz crystals employed in this study were purchased from International Crystal Manufacturing Co., Oklahoma City, OK, USA. The crystals have a fundamental resonance frequency (F_0) of 10MHz. They are with a blank diameter of 0.538" and an electrode diameter of 0.201". The crystal surface is polished while mounted and bonded to HC-48/U base (Fig. 4).



Fig. 4 Quartz Crystal

The crystal is connected to a lever oscillator, which was also purchased from International Crystal Manufacturing. The oscillator caused the crystal to oscillate at its F_0 near 10MHz. This oscillator was modified by Mr. Gregg Mulder of Electrical Engineering Department by extending the crystal holder. This modification is to make it is easier to dip the crystal in the solution. The output frequencies were monitored by

Protek C3100 Universal Counter, which also Highly accurate frequency measurements to 2.4GHz. It was with both RS-232 and GPIB interface, which allow it be connected to a PC for data collection.



Fig. 5 Frequency Counter

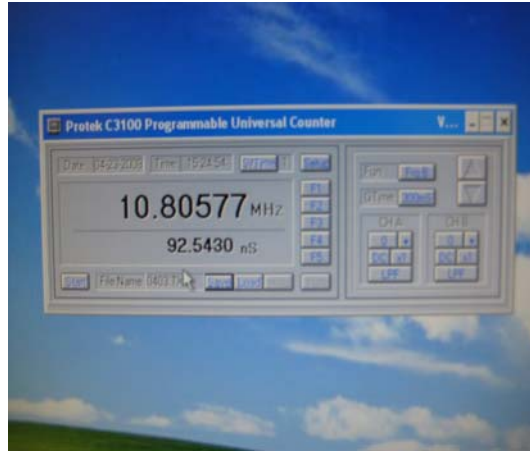

Fig. 6 Data Collection Program

2.2 Flow Cell Design

As illustrated in the theory section, the quartz crystal is usually designed to contact with liquids at one side only (“one-side cell”). This is to eliminate the influences of conductivity, dielectric constant and liquid damping to allow the crystal reach a stable oscillation condition. In order to achieve this one-side operating conditions, a cell must be designed to make sure one side of the crystal be dry and exposed to the air. This cell can either be static or flow cell.

For a static cell, one face of the crystal is exposed to a chamber that can hold up to 1 mL of liquid while the other face is dry and exposed to the air. For a flow cell, so one face of the crystal is exposed to a 70uL chamber. This chamber is connected to an external peristaltic or syringe pumping system. Here we give out a design of flow cell.

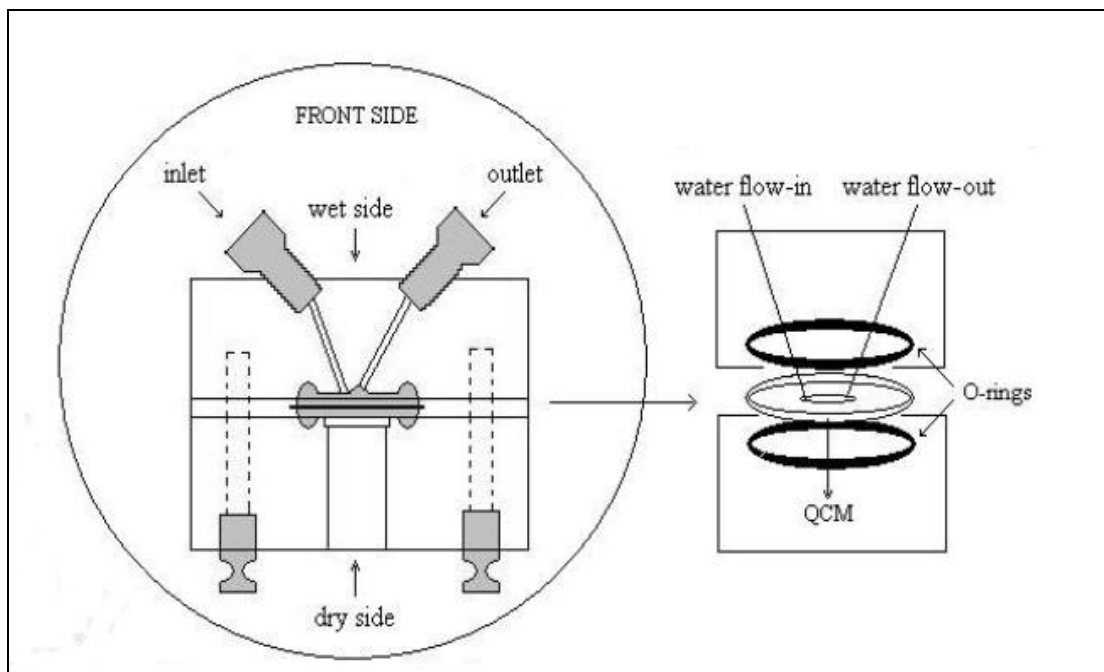

Fig. 7 Flow Cell Design (Talib, 2006)

This flow cell can be built either using Clear Acrylic to provide see-through function or using PEEK (Polyetheretherketone) which provides excellent chemical resistance to organic and inorganic liquids. In this system, crystal was placed between two O-ring for sealing. One side of the crystal will be exposed to air while the other exposed to a liquid chamber.

After the cell is built, it can be connected into the QCM circuit as shown below.

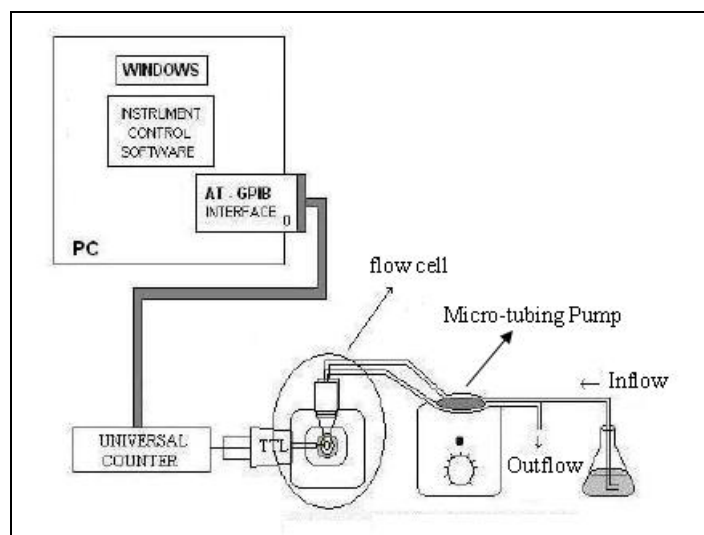

Fig. 8 Experimental setup with flow cell (Adapted from Talib, 2006 with modification)

3. Experimental Protocols for QCM DNA Biosensor

(1) Seal electrodes of QCM with silicon paste/silastic film.

(2) QCM Surface Preparation

The gold QCM surfaces were cleaned by exposure to piranha solution (30% H₂O₂ : H₂SO₄= 1:3, by volume) for 2 min, followed by rinsing with pure water and drying with nitrogen. This process was repeated twice. QCM crystals were used immediately after preparation.

(3) DNA Immobilization

The gold QCM was exposed to an ethanolic 5 mM solution of 3,3'-dithiodipropionic acid for 20 min, followed by water rinsing. 5 µL of 100 mg/mL EDC solution was then placed on the surface, followed immediately by 5 µL of 100 mg/mL NHS solution. These solutions were allowed to interact with the 3,3'-dithiodipropionic acid for 20 min in a 100% humidity environment to prevent solution evaporation. The surface was then rinsed with water and immersed in an aqueous (water solution) 0.2 mg/mL avidin solution for at least 60 min, after which the surface was rinsed again. The QCM was then exposed to a 1 mM 2-aminoethanol solution (pH 8.0, adjusted using HCl) for 60 min, rinsed, and placed into HEPES buffer for DNA immobilization. When the QCM frequency had stabilized, biotin-DNA was injected (final concentration, 1 µg/mL), and the QCM frequency was monitored as a function of time until immobilization was complete, as indicated by a constant (and maximum) frequency shift. The QCM was then removed from solution, rinsed, and used in the hybridization experiments.

(4) DNA Hybridization

QCM immobilized with DNA probe was exposed to HEPES buffer solution, and a solution of complementary DNA was injected (final concentration: 0.5µg/mL). Record the frequency of QCM until it was stabilized.

(5) Dehybridization

The single stranded probe was regenerated by two consecutive treatments of 30s with 1 mM HCl allowing a further use of the sensor.

4. Work in the Future

Further investigations could be made in the following aspects:

- (1) For the casing of QCM in liquid, techniques other than flow cell could be used. For example, rubber casing for QCM (Caruso, 1997; Zhu, 2005) might make the experimental setup simpler.
- (2) For DNA detection, investigation can be made about the specificity of the immobilized DNA probe, i.e., experiment about hybridization with non-complementary DNA can be conducted. For the sensitivity and quantification capacity of QCM DNA biosensor, hybridization with complementary DNA of different concentrations can help to test the response of our sensor, or even calibrate the sensor.
- (3) Another interesting aspect of this DNA sensor is its potential to realize real in situ measurement. For our protocol, the DNA detection process is implemented in specifically prepared buffer solution. Further studies can be conducted to investigate the impacts of solution properties (i.e., ionic strength, pH, temperature) on the performance of the sensor. An suggested alternative approach to realize in situ measurement might be to dilute the field sample solution by specific solution. To do this, adjustment could be made on our experiment setup with flow cell. Another pump can be added to inlet the field sample solution with a flow rate much smaller than that of buffer solution. Then the two solutions are mixed and passed on to the flow cell.
- (4) Other coatings of QCM can also be fabricated to realize detection of different targets.

Acknowledgement

We would like to express our gratitude to Dr. Syed A. Hashsham for his guidance and patience during the experiment of this project.

We sincerely appreciate Mr. Joseph Nyugen for providing all equipment and materials we needed. Without his assistant, we can not finish this project efficiently.

Last we would thank all of our classmates in this lab course, who were always warm-hearted and willing to offer help to us.

References

- Auge, J., Hauptmann, P., Hartmann, J., Rösler, S., Lucklum, R. New design for QCM sensors in liquids. *Sensors and Actuators B*, 1995, 24-25: 43-48
- Caruso, F., Rodda, E., Furlong, D. N., Niikura, K., Okahata, Y. Quartz crystal microbalance study of DNA immobilization and hybridization for nucleic acid sensor development. *Analytical Chemistry*, 1997, 69: 2043-2049
- Caruso, F., Serizawa, T., Furlong, D. N., Okahata, Y. Quartz crystal microbalance and surface plasmon resonance study of surfactant adsorption onto gold and chromium oxide surfaces. *Langmuir*, 1995, 11: 1546-1552
- Dupont-Filliard, A., Billon, M., Livache, T., Guillerez, S. Biotin/avidin system for the generation of fully renewable DNA sensor based on biotinylated polypyrrole film. *Analytica Chimica Acta*, 2004, 515: 271-277
- Eun, A. J. C., Huang, L. Q., Chew, F. T., Li, S. F. Y., & Wong, S. M. 2002. Detection of two orchid viruses using quartz crystal microbalance (QCM) immunosensors. *Journal of Virological Methods*, 99(1-2): 71-79.
- Kanazawa, K. K. and Gordon, J. G. Frequency of a quartz microbalance in contact with liquid. *Analytical Chemistry*, 1985, 57: 1771-1772
- Lazerges, M., Perrot, H., Zeghib, N., et al. In situ QCM DNA-biosensor probe modification. *Sensors and Actuators B*, 2006, 120: 329-337
- Lee, Y. G. & Chang, K. S. 2005. Application of a flow type quartz crystal microbalance immunosensor for real time determination of cattle bovine ephemeral fever virus in liquid. *Talanta*, 65(5): 1335-1342.
- Mannelli, I., Minunni, M., Tombelli, S., Wang, R., Spiriti, M. M., Mascini, M. Direct immobilization of DNA probes for the development of affinity biosensors. *Bioelectrochemistry*, 2005, 66: 129-138
- Spetz, A, 2006, *Chemical Sensor Technologies*, Tutorial 2006
- Su, C. C., Wu, T. Z., Chen, L. K., Yang, H. H., & Tai, D. F. 2003. Development of immunochips for the detection of dengue viral antigens. *Analytica Chimica Acta*, 479(2): 117-123.
- Susmel, S., O'Sullivan, C. K., & Guilbault, G. G. 2000. Human cytomegalovirus detection by a quartz crystal microbalance immunosensor. *Enzyme and Microbial Technology*, 27(9): 639-645.

Takahashi, S., Matsuno, H., Furusawa, H., Okahata, Y. Kinetic analyses of divalent cation-dependent EcoRV digestions on a DNA-immobilized quartz crystal microbalance. *Analytical Biochemistry*, 2007, 361: 210-217

Talib, Z. A., Baba, Z., Kurosawa, S., Sidek, H. A. A., Kassim, A., Yunus, W. M. M. Frequency behavior of a quartz crystal microbalance (QCM) in contact with selected solutions. *American Journal of Applied Sciences*, 2006, 3(5): 1853-1858

Towery, R. B., Fawcett, N. C., Evans, J. A. Determination of chloroplast DNA in a cultured soybean line using a QCM biosensor. *IEEE Sensors Journal*, 2004, 4(4): 489-493

Uttenthaler, E., Schraml, M., Mandel, J., & Drost, S. 2001. Ultrasensitive quartz crystal microbalance sensors for detection of M13-Phages in liquids. *Biosensors & Bioelectronics*, 16(9-12): 735-743.

Zhou, X. C., Huang, L. Q., Li, S. F. Y. Microgravimetric DNA sensor based on quartz crystal microbalance: comparison of oligonucleotide immobilization methods and the application in genetic diagnosis. *Biosensors & Bioelectronics*, 2001, 16: 85-95

Zhu, L., Gao, Y., Shen, H., Yang, Y., Yuan, L. A quartz crystal microbalance (QCM) study of single-strand DNA hybridization and hydrolytic cleavage. *Journal of Analytical Chemistry*, 2005, 60(8): 780-783

http://www.q-sense.com/qcm_d_technology--32.asp

<http://www.aboutus.org/Q-sense.com>

<http://www.yb.gmm.gu.se/method.php?ID=3>

Appendix: Experimental Reagents

Item	Formal Name	Concentration	Other Parameters
Water	Obtained from Milli-Q system		<1 μ S
HCl	HCl for dehybridization	1mM	
Piranha Solution	30% H ₂ O ₂ :H ₂ SO ₄ =1:3		Prepare small volumn with great caution
EDC	N-Ethyl-N-(3-(dimethyl)aminopropyl)carbodiimide hydrochloride	100mg/mL	AR Grade
NHS	N-hydroxysuccinimide	100mg/mL	AR Grade
3,3'-Dithiodipropionic acid	3,3'-Dithiodipropionic acid	5 mM	ethanolic solution
2-aminoethanol	2-aminoethanol	1 mM	pH=8.0, adjusted using HCl
HEPES buffer	4-(2-hydroxyethyl)-1-piperazineethanesulfonic acid	0.05 M	pH=7.5, ionic strength 0.1 M, containing 0.024 M NaOH and 0.076 M NaCl
avidin	Avidin from Egg White	0.2 mg/mL	
biotinylated DNA	Biotinylated at 5'-phosphate end. <i>Aeromonas hydrophila</i> bvgS ₁₄ GTACAGCCCTACTATGACCTGGAGGGAAATGTTCAGGGTGGGAATCGGTGG	final concentration 1 μ g/mL	
Target DNA	Complementary DNA for the probe (final concentration 0.5 μ g/mL).		
Non-complementary DNAs	Some DNAs to test the specificity of the probe.		
silicon paste/silastic film	protect electrical contacts		