

MICHIGAN STATE  
UNIVERSITY

MICHIGAN STATE UNIVERSITY *Fall 2012*

# Design Day

COLLEGE OF ENGINEERING



*Executive Partner Sponsor of Design Day*



## Auto-Owners Insurance Campus in Lansing

Dear Students, Family Members, Company Representatives, Alumni, Faculty & Staff:

On behalf of Auto-Owners Insurance, and in partnership with Michigan State University, it gives us great pleasure to welcome you to the beautiful MSU campus and specifically to the MSU College of Engineering Design Day. We are pleased and honored to partner with Michigan State University in this program, which showcases the talents and abilities of many gifted students.

It has been said the future belongs to the youth. If this is the case, (which we believe to be true) by the creativity, imagination, and initiative displayed by the participating students in this year's Design Day Program, you have to admit the future looks very bright indeed. A tremendous array of skills and abilities will be displayed this year, which further substantiates our continued support of this program. We congratulate each participant along with those who have provided support, guidance and instruction to them.

As a recruiter of talent for the ongoing needs of our Company, we could not be more pleased with programs like Design Day, or the constant exposure to creative thinking that is provided through the daily course work at Michigan State University. We hire many graduates from numerous disciplines at MSU, and find them to be dedicated, hard working individuals who quickly become solid members of our team. We could not be more proud. Auto-Owners Insurance has called Michigan home since our beginning in 1916. We consider ourselves, along with Michigan State University, one of the great success stories in this state. This year we were rated "Highest in Customer Satisfaction with the Auto Insurance Claims Experience, Five Years in a Row" by J.D. Power and Associates. It is because of our outstanding associates that we are able to receive such a great recognition and continue to grow.

We wish you a truly pleasant, exciting and stimulating day here on the MSU campus. May you be thrilled by the talent of the participants as well as the deep heritage of this campus. We at Auto-Owners Insurance join in congratulating all the participants, proud parents, and sponsors who took the initiative to support this program. Our best wishes to all for a wonderful day!

Sincerely,

Jeff Harrold, Chairman & CEO



**"Highest in Customer Satisfaction with the Auto Insurance Claims Experience, Five Years in a Row."**

**- J.D. Power and Associates**

# Auto-Owners Insurance



# Table of Contents: December 7, 2012

---

<i>Welcome from the Dean: Dr. Satish Udpa</i> .....	2
<i>Design Day Events Schedule and Union Building Floor Plan: Friday, December 7, 2012</i> .....	3-4
<i>The Dart Foundation Day, December 7, 2012: Middle School &amp; High School Events Schedule</i> .....	5-7
<i>EGR 100 Introduction to Engineering Design: Course Project</i> .....	8
<i>CE 495 Senior Design in Civil Engineering: Projects and Presentation Schedule–MSU and Lake Michigan Rooms</i> .....	9-11
<i>Computer Science and Engineering: Capstone Course Sponsors</i> .....	12
<i>CSE 498 Computer Science &amp; Engineering Projects: Presentation Schedule–Lake Ontario Room</i> .....	13
<i>Auto-Owners Insurance: Pig “E” Bank</i> .....	14
<i>The Boeing Company: Design, Fly and Compete Sim Suite V2.0</i> .....	15
<i>The Ford Motor Company: MyKey Report Card</i> .....	16
<i>GE Aviation: Mobile Avionics Satellite Imagery</i> .....	17
<i>Google: Indexing System Mobile Dashboard</i> .....	18
<i>Meijer: IT ePager System</i> .....	19
<i>Mozilla Corporation: Reader Mode for Desktop Firefox</i> .....	20
<i>Quicken Loans: Secure Note Taking and Collaboration Tools</i> .....	21
<i>Spectrum Health Systems: Medication Shortages Dashboard</i> .....	22
<i>TechSmith: Snagit Power Tools</i> .....	23
<i>Urban Science: Mobile Geography Management</i> .....	24
<i>Whirlpool: Connected Appliances Analytics Dashboard</i> .....	25
<i>Computer Science and Engineering: Design Day Awards Spring 2012</i> .....	26-27
<i>ECE 480 Electrical &amp; Computer Engineering Projects: Presentation Schedule–Heritage Room</i> .....	31
<i>Air Force Research Laboratory: Equipment Rack Active Cooling System</i> .....	32
<i>Air Force Research Laboratory: Human Electromagnetic Scattering Simulator</i> .....	33
<i>Resource Center for Persons with Disabilities: Haptic User Interface</i> .....	34
<i>Resource Center for Persons with Disabilities: Branden’s Detented Joystick</i> .....	35
<i>ArcelorMittal S.A.: Load Metering and Transmission</i> .....	36
<i>Texas Instruments: Electrocardiograph Demonstration Board</i> .....	37
<i>Instrumented Sensor Technology Inc.: User Settable G-Switch</i> .....	38
<i>MSU Technologies: GUIMoo: GUI for Moo RFID Sensor Platforms</i> .....	39
<i>Texas Instruments: Robotic Transportation Vehicle</i> .....	40
<i>Electrical and Computer Engineering: Design Day Awards</i> .....	41
<i>ME 371 Mechanical Design I: Thrills for Pre-Collegiates: Mechanisms that Fascinate, Captivate, Stimulate and Entice</i> .....	44
<i>ME 412 Heat Transfer Laboratory: Solar Water Heater</i> .....	45
<i>ME 456 Mechatronics Systems Design: Prototypes of Commercial Products</i> .....	46
<i>ME 471 Mechanical Design II: Horizontal Motion Conveyor System</i> .....	47
<i>ME 481 Mechanical Engineering Design Projects: Presentation Schedule–Lake Superior Room</i> .....	49
<i>Ford Motor Company: Diesel Fuel Injection Systems Air Separator</i> .....	50
<i>Chrysler Group LLC: Retractable Seat Insert for Comfort</i> .....	51
<i>Robert Bosch, LLC: Test Rig for Analysis of Diesel Injector Sprays</i> .....	52
<i>United States Steel – Great Lakes Works: Automated Measurement of Pipe Inner Diameters</i> .....	53
<i>Williams International, LLC: Design of a Quieter Test-Cell Air Intake</i> .....	54
<i>ZF Lemforder Corporation: A Tool for Ball-Joint Torque Measurement</i> .....	55
<i>Whirlpool Corporation: Ice and Water Dispensation from Refrigerators</i> .....	56
<i>Whirlpool Corporation: Door that Eliminates Line Disconnections</i> .....	57
<i>Haworth Inc.: Design of a Moveable Wall System</i> .....	58
<i>General Motors Foundation: Pedestrian Sound Simulator for Electric Vehicle</i> .....	59
<i>U.S. Air Force Research Laboratory: Active Cooling Control of Electrical Racks</i> .....	60
<i>Mechanical Engineering: Design Day Awards</i> .....	62-63

# Welcome from the Dean



## **As Dean of the College of Engineering, on behalf of the entire faculty, we welcome you to Design Day!**

We wish you an enjoyable event as you experience our students and their amazing talents through presentations, competitions, demonstrations and posters.

We are pleased to recognize Auto-Owners Insurance as our Design Day Executive Partner Sponsor for the seventh consecutive semester. We welcome Whirlpool Corporation as a first-time Design Day Directing Partner Sponsor. Our Design Day Supporting Partner Sponsors include Bosch, Dow Chemical Corporation, Michigan State University Athletics, Michigan State University Federal Credit Union and Quicken Loans. We thank all of our sponsors for their generosity and their ongoing commitment to Design Day.

As you explore the exhibits throughout the MSU Union, you are encouraged to take time to learn about the projects by talking with our students. They are an incredible group of people who love to share their enthusiasm for engineering.

Starting in their first semester, our freshmen learn about the importance of engineering and the positive impact that engineers make on society and the world around them in our Cornerstone and Residential Experience for Spartan Engineers program. Be sure to stop by and see how they innovate, communicate and perform at the highest levels in an increasingly global and demanding world.

Another exciting part of Design Day is the Dart Foundation Day of Engineering Innovation and Creativity for 7th-12th Grade Students, which involves some 200 local junior high and high school students. On Design Day, these future engineers explore design principles with hands-on projects requiring the application of their creativity and ingenuity.

The headliners of Design Day are our graduating seniors as they present their design projects through exhibits, posters and presentations. Their projects represent the capstone of their educational career. You will see that our graduating MSU engineers are ready to lead, create and innovate.

Our capstone programs and Design Day would not be possible without the continued support of our capstone project sponsors who provide both funding and a professional experience for our capstone design teams. We appreciate their generosity and their time.

Please join us for the Design Day Awards Ceremony in the MSU Union Ballroom at 1:15 pm when we will honor all of our talented Spartans, the best of the best.

A handwritten signature in blue ink that reads "Satish Udpa".

**Dr. Satish Udpa**

Dean of the College of Engineering  
University Distinguished Professor  
Michigan State University

# Design Day Events Schedule

## Friday, December 7, 2012

EVENTS	8 a.m.	9 a.m.	10 a.m.	11 a.m.	Noon	1 p.m.
Engineering Student Organizations		2nd Floor Concourse 9:00 a.m. – Noon				
EGR 100 Presentations		2nd Floor Ballroom 9:00 a.m. – 11:30 a.m.				
ME 371 Demonstrations		2nd Floor Gold Rooms A & B 9:00 a.m. - Noon				
ME 412 Competition		2nd Floor Parlor A 8:30 a.m. - 12:15 p.m.				
ME 456 Presentation	4th Floor Tower Room 8:00 a.m. - 12:05 p.m.					
ME 471 Competition	2nd Floor Ballroom 8:00 a.m. - Noon					

CAPSTONE COURSES						
All Capstone Posters	1st Floor Lounge 8:00 a.m. - Noon					
CE 495 Project Presentations	3rd Floor Lake Michigan Room 8:00 - Noon					
CE 495 Project Presentations	3rd Floor MSU Room 8:00 - Noon					
CSE 498 Project Presentations	3rd Floor Lake Ontario Room 8:00 a.m. - 11:45 a.m.					
ECE 480 Project Presentations	Garden Level, Heritage Room 8:00 a.m. - Noon					
ME 481 Project Presentations		3rd Floor Lake Superior Room 8:30 a.m. - Noon				

LUNCH AND AWARDS						
High School Awards		Parlor C Noon - 12:10 p.m.				
MSU Lunch		2nd Floor Concourse 12:15 p.m. - 1:00 p.m.				
MSU Awards		Ballroom 1:15 p.m.- 2:00pm.				



### Social Media Links:

"Like" the College: <https://www.facebook.com/SpartanEngineering>

"Follow" the College: [https://twitter.com/msu\\_egr\\_news](https://twitter.com/msu_egr_news)

### To stay up to date w/Careers in Engineering:

"Like" Us <http://www.facebook.com/pages/The-Center-for-Spartan-Engineering/226159694117936>

"Follow" Us: <https://twitter.com/msuengineer>

# Design Day Floor Plans of the MSU Student Union

Ground Floor

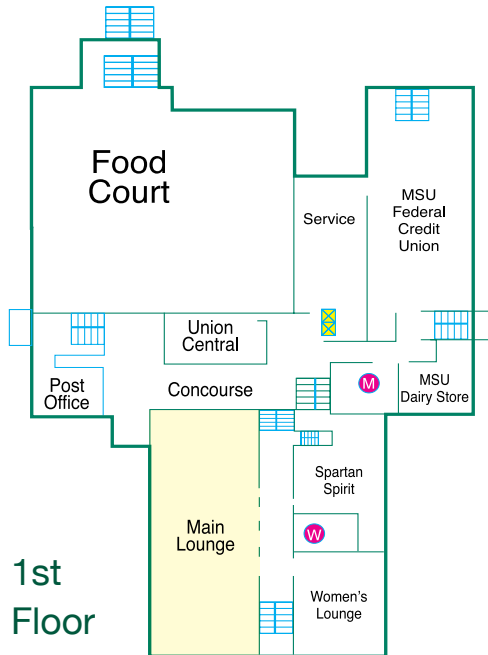
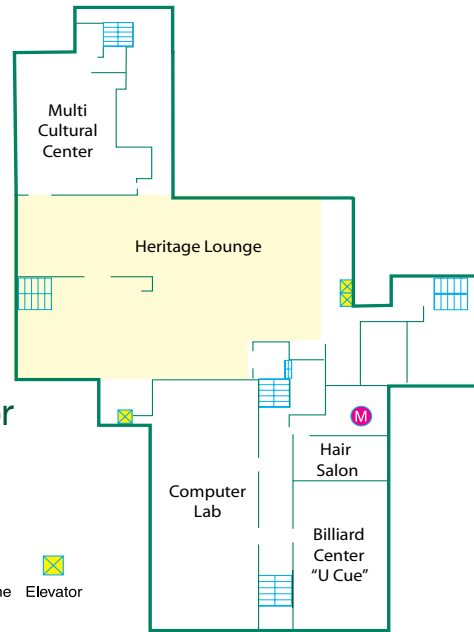
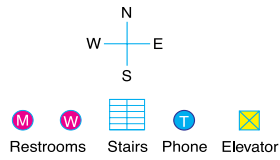

1st Floor

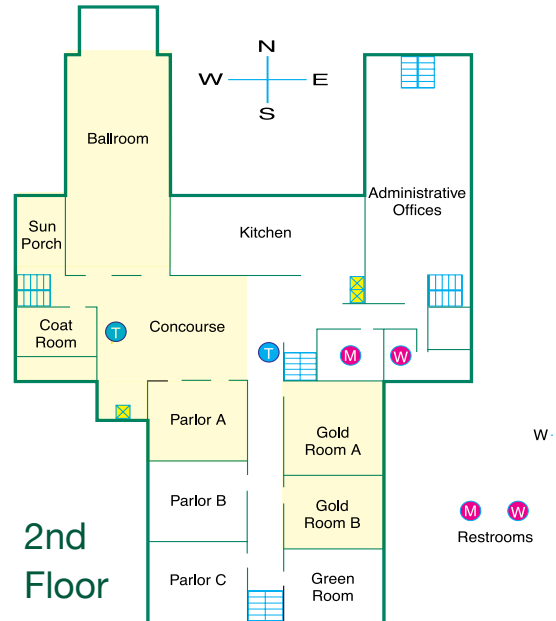

2nd Floor

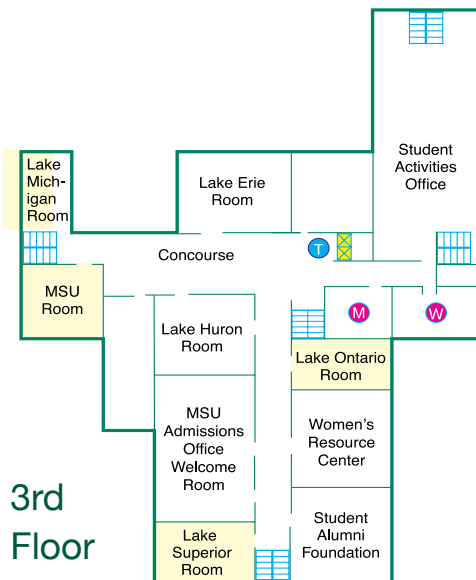

3rd Floor

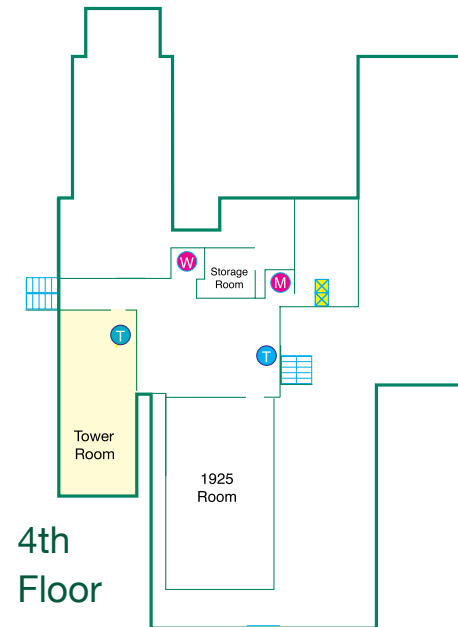

4th Floor

# Dart Day of Innovation and Creativity *for 7th-12th Grade Students*



## **Our Future Lies in Some Very Precious Hands...**

At the Dart Foundation, we are committed to developing scientifically literate students in Michigan. We're proud to sponsor the MSU College of Engineering Design Day for pre-collegiate students.

Funded by the Dart Foundation



MICHIGAN STATE UNIVERSITY | College of Engineering

# The Dart Foundation

## Middle and High School Innovation and Creativity Day

**Precollege Student Voting:** During the morning on Design Day all visiting precollege students will be viewing Engineering Projects and voting.

During this time college students will have a chance to interact with “non-engineering” students and demonstrate the underlying principles from their projects. This interaction allows the college students an opportunity to practice explaining engineering concepts to non-engineers. As the precollege students work their way through the wide variety of presentations, they will get an overview of the many different branches of engineering. Additionally, as the precollege students see both entry-level and advanced engineering applications, it allows them to see the natural progression of engineering. Lastly, this session also provides a chance for the precollege students to interact with student organizations within the College of Engineering.



NSF funded Research Experiences for Teachers (RET) Site Workshop 9 a.m. - Noon	
9:00-9:55	Welcome and Summer Institute Teacher Curriculum presentations
10:00-10:55	VEX Robotics and Interdisciplinary Engineering Builds
11:00-11:55	Engineering Student Project Viewing and Voting
12:00-12:10	Award ceremony in Parlor C

<http://www.egr.msu.edu/future-engineer/>  LIKE US: <https://www.facebook.com/futurespartanengineers>



## VEX ROBOTICS

Our team of experts has designed a lab experience to give precollege students an introduction to robots. Students will work in small groups and have a hands-on approach learning to control the VEX robot. They will write programs using Robot C language, and they will program the robot to be controlled by a remote control. Application and discovery of how programming works will be similar to lessons presented in science and math classes. Each team will discover how to adjust their programs based upon the program inputs and actual output (robot performance). During each phase, new challenges will be introduced to engage the students. This will reinforce new ideas and concepts while exposing students to the newly emerging capabilities of student-controlled robotics programs.

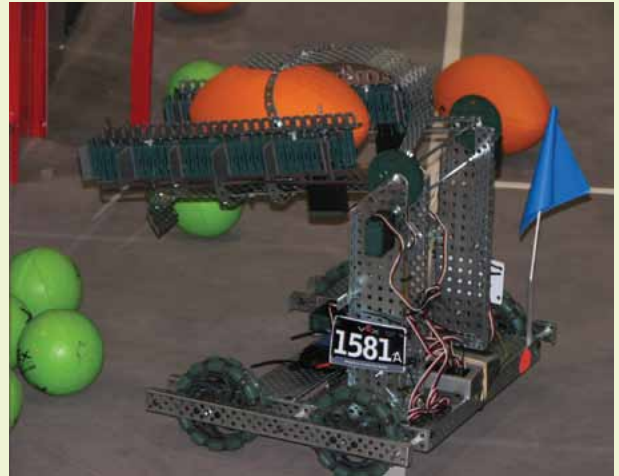

## INTERDISCIPLINARY ENGINEERING BUILD

In this build you and your team will be integrating practices from multiple fields of engineering to build and evaluate a support system. Support systems can range from simple beams to intricate bridges composed of gussets, trusses, cables, etc. These types of systems are used throughout Civil, Mechanical and Structural Engineering works. This session will start with a brief introduction to the forces and stresses that act on support systems. Additionally, you will see how digital sensors can read and convey data about these stresses to a computer. We will also look at the computer code that takes this raw data and converts it into a format that can easily be interpreted.

During the build portion of this session you and your team will be given the design constraints for the structure. Utilizing the information learned at the start of the session and the limited materials provided, your team will need to design and then construct a model to be tested. Your finished structure will be placed on one of our test beds for evaluation. With the help of MSU Engineering students, the results will be collected by a sonic ranging sensor. These data points will be interpreted by the computer program and your team will be evaluated on percent deflection of your support. Throughout this session you will need to listen, learn and utilize your team to be successful. Good Luck.



## MEMBERS OF THE ORGANIZING COMMITTEE



**Drew Kim**  
MSU Engineering  
Assistant to the Dean  
Recruitment, Scholarships,  
and K-12 Outreach



**Luis Donadoto**  
Assistant Director of  
MSU Engineering  
Recruitment and  
K-12 Outreach



**Jamie Lynn Marks**  
MSU Engineering  
Recruitment and  
K-12 Outreach



**Russ Pline**  
Okemos High School  
and MSU Engineering  
Recruitment and K-12  
Outreach Design Day  
Coordinator



**Jung Sung,**  
Education and  
Technology  
Consultant



**Bob Watson**  
MSU Engineering  
K-12 Outreach  
LEGO and VEX  
Robotics Coordinator



## EGR 100 Introduction to Engineering Design

**Mr. Timothy Hinds**  
Academic Director

### Course Project

EGR 100, Introduction to Engineering Design, is a college-level course required of all incoming first-year engineering students. It is an integral part of the CoRe (Cornerstone and Residential Experience). The course introduces students to the engineering profession and the engineering design process through team-based, interdisciplinary design projects and assignments. Nearly 800 students are enrolled in EGR 100 this semester.

For the final course project, the student teams selected from four project types: (i) thermal insulator design, (ii) Lego® Mindstorms® competition, (iii) renewable energy and (iv) MSU Resource Center for Persons with Disabilities (RCPD) design. For the first choice, the student teams were to design, build and test a thermal insulator that would minimize the temperature increase of a given volume of water exposed to a heat source. The second choice required the students to build and program an autonomous robot that competes simultaneously against other robots to gather high-scoring, colored balls. For the third project type, teams of students used solar and wind energy to power robotic material handling vehicles. The final type had teams work with RCPD clients to design and build working prototypes to assist the clients in daily activities. Teams from each of the project types will display their prototypes at Design Day along with posters detailing their design concepts. Pre-college students will recognize the most outstanding projects with awards.



#### Spring 2012 EGR 100 Project Poster Award Winners:

Mark Main, Jiacheng Peng, Casey Reagan, Tony Secinaro



<http://www.egr.msu.edu/core/>



# The Capstone Projects

**Dr. Roger Wallace**  
Professor of  
Civil Engineering

## Presentation Schedule – MSU Room and Lake Michigan Room

Time	Team	Room
8:00 a.m.	Team One	The MSU Room
8:00 a.m.	Team Two	The Lake Michigan Room
9:20 a.m.	Team Three	The MSU Room
9:20 a.m.	Team Four	The Lake Michigan Room
10:40 a.m.	Team Five	The MSU Room
10:40 a.m.	Team Six	The Lake Michigan Room

## CE 495 Senior Design in Civil Engineering

Undergraduates in civil engineering must take CE 495. This capstone course prepares students for the work place by providing an experience with the following challenges:

- A project with multiple issues that must be resolved using civil engineering knowledge;
- Formulation of conceptual solutions and resolution of conflicting design elements;
- Development of plans that comply with regulations and provide a basis for cost estimates;
- Balancing individual responsibility and group participation in a team based effort;
- Preparation of written reports and oral presentations.

Engineers and scientists associated with the following employers donated time to provide students with a practicing professional's perspective: Bergmann Associates; Consumers Energy; East Lansing Dept of Public Works; Fishbeck, Thompson, Carr & Huber; Harley Ellis Devereaux; HNTB; J F New; NTH Consultants; MSU; Soil & Materials Engineers; Tetra Tech MPS; and URS Corporation. We gratefully acknowledge their generous contributions.

# CE 495 SENIOR DESIGN IN CIVIL ENGINEERING

## PROFESSIONAL EVALUATORS

Engineers and scientists associated with the following firms, municipalities, and companies donated time to provide students with a practicing professional's perspective: Bergmann Associates; Consumers Energy; East Lansing Department of Public Works; Fishbeck, Thompson, Carr & Huber; HNTB; MSU Physical Plant; NTH Consultants; Soil & Materials Engineers; Tetra Tech MPS; and URS Corporation. We gratefully acknowledge their generous contributions.

Len Becker, PE  
HNTB  
Detroit, MI

Rick Chelotti, PE  
Bergman Associates  
Lansing, MI

Daniel Christian, PE  
Tetra Tech MPS  
Lansing, MI

Andrew Hermiz, EIT  
Harley Ellis Devereaux  
Southfield, MI

Scott Dierks, PE  
JF New  
Ann Arbor, MI

Matt Junak, PE  
HNTB  
E. Lansing, MI

Stu Kogge, PWS  
JF New  
Ann Arbor, MI

Thomas Larder, PE  
Process Results, Inc.  
Saline, MI

John LeFevre, PE  
MSU Physical Plant.  
Lansing, MI

Peter Margules, PE  
NTH Consultants  
Northville, MI

George McKenzie, PE  
Consumers Power  
Jackson, MI

Stephanie O'Donnell, EIT  
MSU  
E. Lansing, MI

Todd Sneathen, PE  
Director of Public Works  
E. Lansing, MI

Michael J. Thelen, PE  
Soil & Materials Engineers, Inc.  
Lansing, MI

Anthony Thomas, PE  
Soil & Materials Engineers, Inc.  
Shelby Twp., MI

Award  
Sponsors

BARR

ftc&h

## Civil Engineering Civil Design Award

The Civil Engineering Senior Design Award (\$700 and plaques) is presented to the best team as judged by the faculty and a panel of practicing engineers.

Each team is responsible for developing a design that addresses environmental, geotechnical, hydrological, pavement, transportation, and structural issues for the project. A student project manager coordinates each team. Design reports are judged by the faculty; progress reports and the oral presentations are judged by a board of practicing professionals.

The faculty and students of the Department of Civil and Environmental Engineering gratefully acknowledge the generous contributions from Fishbeck, Thompson, Carr & Huber, Inc. (FTC&H) and from Barr Engineering Co. These companies currently make this award possible. FTC&H is a professional civil engineering, environmental consulting, architectural/engineering, and construction management firm with clients in Michigan and throughout the nation. Barr Engineering is a professional engineering company providing engineering, environmental, and information technology services to clients across the nation and around the world.

# Michigan State University Student Apartment Complex Designs

Student-teams developed preliminary designs for elements of a 144-unit student apartment complex located east of campus near the Red Cedar River. Two configurations were considered: One would employ three buildings, each with a paved, uncovered, interior court yard that is used for parking; building height is limited to three stories above ground in order that wood frame construction can be employed. The second alternative would provide the same number of housing units in a more compact configuration that placed some parking within each building's footprint; these buildings required at least four stories above ground which necessitates steel and/or concrete structures. Teams provided preliminary design for key structural elements of the buildings and their foundations; for road and intersection geometry, as well as; the pavement design; for an enhanced pedestrian and bike pathway connecting the development with Grand River and the MSU campus; and for improvements to the existing mitigation-wetland.



**Team 1:** I-r: Sarah Mozdrzech, Kyle Kammermeier, John Blake, Colton Wallace, Rudy Supanich, Scott Crichton



**Team 2:** I-r: Jacob Darnall, Michael Krcmarik, Emily Sokol, Mathew Howland, Sherouq Aldamkhi, Samer Naser, Robert Binder



**Team 3:** I-r: Erik Easterly, Ryan Bair, Michael D'Orazio, Sharif Gushgari. Front row (l-r): Jayme Rubley, Rodney Dennis, Ryan Graham

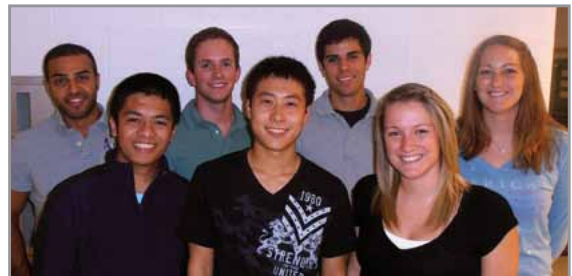

**Team 4:** I-r: Hussain Bokhamseen, Mike Prohaska, Josh Johnson, Emily Schneider. Front row (l-r): Ronell Eisma, Japson Gu, Allie Masters



**Team 5:** I-r: James Maier, Mark Alberty, Aaron Chamberlain, John Bort. Front row (l-r): David King, Travis Satkowiak, Ashley Roberts



**Team 6:** I-r: John Alilin, Dan Helou, Buddy Sheffer, John Nadjarian. Front row (l-r): Brian Richey, Sarah Sharawi, Jessica Holberg

## Computer Science and Engineering

# Capstone Course Sponsors

We thank the following companies for their generous support of the computer science capstone course.

**Auto-Owners Insurance**  
Lansing, Michigan



**The Boeing Company**  
St. Louis, Missouri



**The Ford Motor Company**  
Dearborn, Michigan



**GE Aviation**  
Grand Rapids, Michigan



**Google**  
Mountain View, California



**Meijer**  
Grand Rapids, Michigan



**Mozilla Corporation**  
Mountain View, California



**Quicken Loans**  
Detroit, Michigan



**Spectrum Health Systems**  
Grand Rapids, Michigan



**TechSmith**  
Okemos, Michigan



**Urban Science**  
Detroit, Michigan

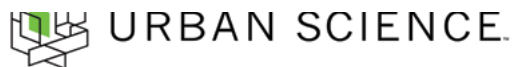

**Whirlpool**  
Benton Harbor, Michigan





## The Capstone Projects

**Dr. Wayne Dyksen**  
Professor of Computer Science and Engineering

### Presentation Schedule – Lake Ontario Room

Time	Team Sponsor	Project Title
7:30 a.m.	Auto-Owners	Pig “E” Bank
7:50 a.m.	Boeing	Design, Fly and Compete Sim Suite V2.0
8:10 a.m.	Ford	MyKey Report Card
8:30 a.m.	GE Aviation	Mobile Avionics Satellite Imagery
8:50 a.m.	Google	Indexing System Mobile Dashboard
9:10 a.m.	Meijer	IT ePager System
9:30 a.m.	Break	
9:45 a.m.	Mozilla	Reader Mode for Desktop Firefox
10:05 a.m.	Quicken Loans	Secure Note Taking and Collaboration Tools
10:25 a.m.	Spectrum Health	Medication Shortages Dashboard
10:45 a.m.	TechSmith	Snagit Power Tools
11:05 a.m.	Urban Science	Mobile Geography Management
11:25 a.m.	Whirlpool	Connected Appliances Analytics Dashboard

## CSE 498 Collaborative Design

CSE 498, Collaborative Design, provides the educational capstone experience for all students majoring in computer science. The course objectives include the following:

- Designing, developing, and delivering a comprehensive software system to a client;
- Learning to work effectively in a team environment;
- Developing written and oral communication skills;
- Becoming proficient with software development tools and environments;
- Learning about system building and system administration; and
- Considering issues of professionalism and ethics.

Project sponsors are local, regional, and national, and have included Auto-Owners Insurance, Boeing, Chrysler, Dow, Ford, GE Aviation, General Motors, Google, IBM, Meijer, Microsoft, Motorola Mobility, Mozilla, Plex Systems, Quicken Loans, Raytheon, Spectrum Health Systems, TechSmith, Toro, the Union Pacific Railroad, Urban Science and Whirlpool.

### The Capstone Experience Lab Sponsored By



URBAN SCIENCE.

We thank Urban Science for their generous support of the Capstone Experience Lab.



# Auto-Owners Insurance Pig "E" Bank

Auto-Owners Insurance is a Fortune 500 company that offers many types of insurance including life annuity accounts, which are investment structures designed to provide payments at specified intervals.

Pig "E" Bank is a web application that provides a convenient and easy-to-use way for users to make electronic deposits into annuity accounts. The users may be the annuity account holder or even a family member or friend making a deposit as a gift.

Electronic deposits are made with a simple three-step process. If the deposit is a gift, a user can send an additional small gift like a teddy bear or a note to the annuity account holder. Payment options include credit cards or electronic fund transfers.

Pig "E" Bank works with mobile web browsers. With such accessibility, making deposits into annuity accounts has never been easier or more convenient.

Our system also includes an administrator web site, which is used to track and possibly resolve payments. Payment records can be searched by date and by the account holder's name.

Our Pig "E" Bank web interface is written in HTML and JavaScript. The backend is written in C# using ASP.NET.

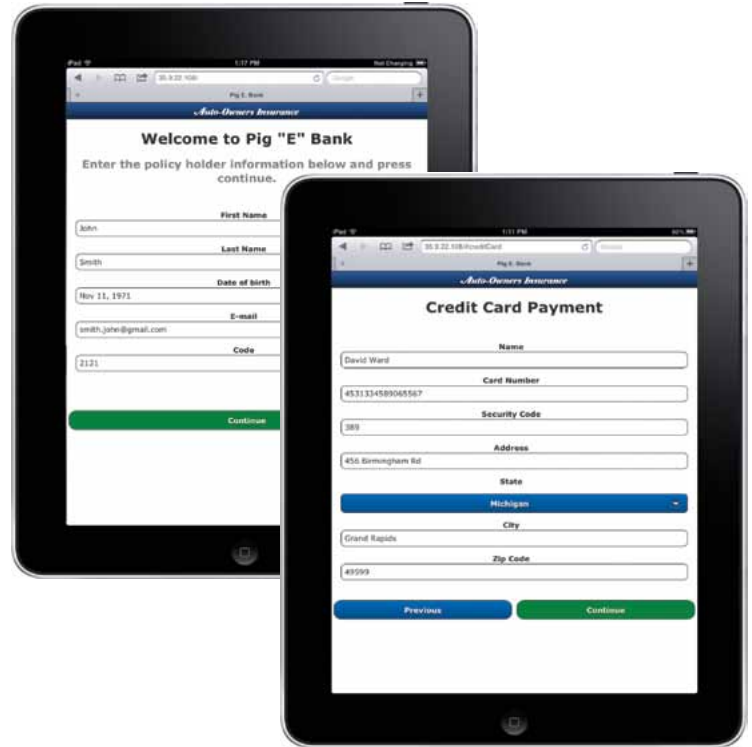

## Michigan State University Team Members (left to right)

**David Ward**  
Fowlerville, Michigan

**Benjamin Szymczak**  
Macomb, Michigan

**Nathan Sriro**  
West Bloomfield, Michigan

## Auto-Owners Project Sponsors

**Bob Buchanan**  
Lansing, Michigan

**Lisa Fricano**  
Lansing, Michigan

**Scott Lake**  
Lansing, Michigan

**Jim Schumacher**  
Lansing, Michigan

**Kamren Zorgdrager**  
Lansing, Michigan



# The Boeing Company

## Design, Fly and Compete Sim Suite V2.0

**B**oeing is the world's leading aerospace company and the largest manufacturer of commercial jetliners and military aircraft combined.

Research and development of new products represent significant investments for Boeing. In addition, training users on existing products represent significant investments for Boeing customers. To minimize time and maximize efficiency, Boeing utilizes complex modeling and simulation software systems.

Design, Fly and Compete Sim Suite V2.0 is a flight simulator that features six degrees of freedom with realistic physics of flight. Players can choose from four different planes to navigate through nine different obstacle courses. A new feature of V2.0 is a multiplayer mode where players can interact with each other via an internet connection.

In addition to a standalone Microsoft Windows desktop version, our flight simulator also includes a web version, which runs in both Chrome and Safari for use on Desktops, iPhones, and iPads. Our web version is designed with extensions to provide an immersive feature-filled user experience.

The Microsoft Windows desktop application utilizes the Qt framework and OpenSceneGraph for the application and DIS and HLA for networking. The browser version uses HTML5, JavaScript and WebGL for the application and Socket.IO for communication.

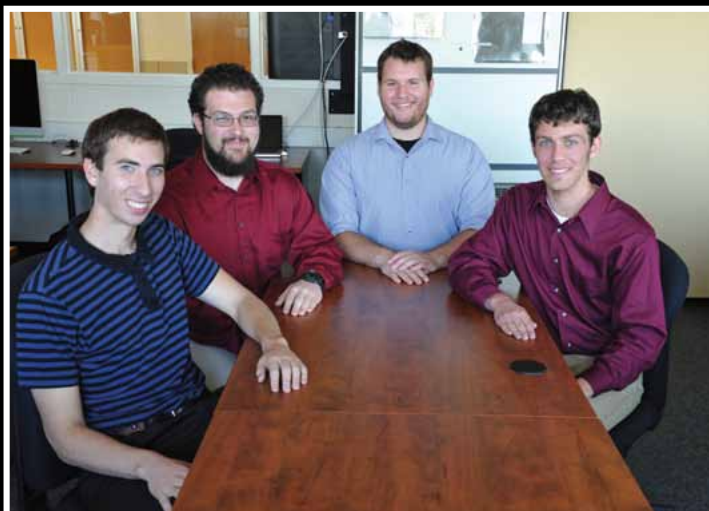

### Michigan State University

*Team Members* (left to right)

**Dan Sosnowski**  
Shelby Township, Michigan

**Kevin Liening**  
Warren, Michigan

**Max Ellison**  
Canton, Michigan

**Jake Newsted**  
Haslett, Michigan

### Boeing

*Project Sponsors*

**Pete Clive**  
Saint Louis, Missouri

**Matt Daniels**  
Saint Louis, Missouri

**Jayson T. Vincent**  
Saint Louis, Missouri

**Steve Yallaly**  
Saint Louis, Missouri

# The Ford Motor Company MyKey Report Card

Founded in 1903, the Ford Motor Company is a Fortune 500 company that develops and produces some of the most innovative cars and trucks in the world.

One such innovation is the Ford MyKey system, which allows owners to program a key that sets safety restrictions for each driver. For example, owners can limit the top speed of a car or the maximum volume of the radio.

As an addition to the Ford MyKey system, our MyKey Report Card provides owners with a report card of the driving habits of each of a car's drivers by collecting data from the vehicle using an Android phone or tablet.

Users view the report cards using the MyKey Report Card web site. Users can customize the data displayed on their report cards and specify additional methods of report card delivery. Users can set emergency notification options that send text messages or e-mail if a vehicle exceeds a specified threshold.

The MyKey Dashboard, an Android application that supplies driver data from the vehicle, displays real-time data in a virtual instrument panel while sending driving data to a centralized database.

The MyKey Report Card website is written in HTML5 and Java EE 6. The driving data is stored using SQL Server 2008. The Android application uses the Android SDK and OpenXC vehicle interface, which enables an Android device to receive data from a vehicle.



## Michigan State University

*Team Members* (left to right)

**Kevin Klemmer**  
Grand Rapids, Michigan

**Andrew Crouch**  
Lansing, Michigan

**Brandon D'Orazio**  
Lake Zurich, Illinois

**Alex Conklin**  
Milford, Michigan

## Ford

*Project Sponsors*

**Adam Haas**  
Dearborn, Michigan

**Michael Seneski**  
Dearborn, Michigan

**Michael Volk**  
Dearborn, Michigan

# GE Aviation

## Mobile Avionics Satellite Imagery

By using state-of-the-art digital technology, GE Aviation is meeting the needs of the world's evolving airspace. Their products offer the flexibility and enhanced performance that are essential in safety-critical aircraft operations.

The Federal Aviation Administration (FAA) has approved the use of iPads by pilots, which allows state-of-the-art mobile technologies to provide innovative replacements for outdated technologies along with a host of new ones.

When pilots must fly to remote areas or unfamiliar airports, ultra-high-resolution satellite images can provide valuable visual insights about the airport and the area surrounding their destination.

Our Mobile Avionics Satellite Imagery iPad app provides a convenient way of displaying and manipulating GE Aviation's ultra-high-resolution satellite images. The app incorporates the use of familiar touch screen gestures as well as the ability to display the latitude and longitude of any point in the image as shown in the example to the right.

The iPad app provides pilots with information in a way that is more convenient and lightweight than the equivalent paper maps while taking advantage of the image quality that an Apple iPad has to offer.

Our Mobile Avionics Satellite Imagery iPad app is written in Objective-C. The images are preprocessed by an application written in C++ and follow the GeoTIFF image specification.



Image © GeoEye

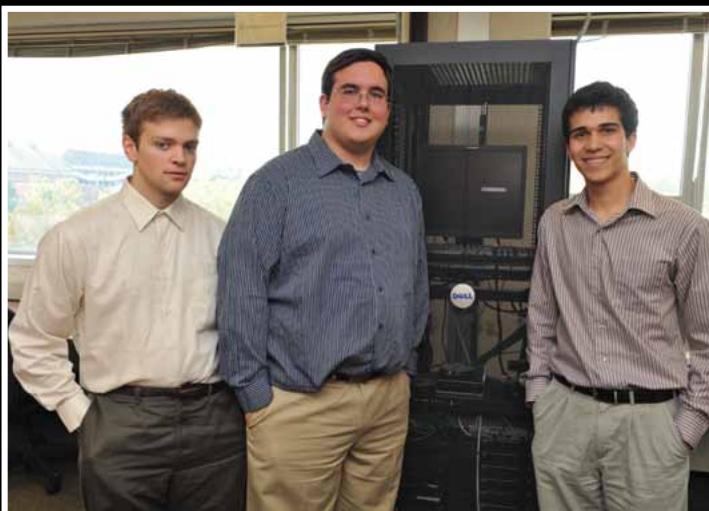

### Michigan State University

*Team Members* (left to right)

**Andy Matteson**  
Ann Arbor, Michigan

**Zack Pepin**  
Marysville, Michigan

**Mateus Braga**  
Brasilia, DF, Brazil

### GE Aviation

*Project Sponsors*

**Benjamin Bufford**  
Grand Rapids, Michigan

**Dotie Hall**  
Grand Rapids, Michigan

**Vaughn Harmon**  
Seattle, Washington

**Dashiell Kolbe**  
Grand Rapids, Michigan

# Google Indexing System Mobile Dashboard

Google's mission is to organize the world's information and make it universally accessible and useful. This is made possible through various support tools including Google's indexing system dashboard.

The dashboard monitors and displays information about various Google systems to ensure continuous smooth operation. Google uses an online dashboard system that requires the indexing network engineers to carry a laptop computer at all times in order to access the dashboard.

Our Indexing System Mobile Dashboard provides the capability of monitoring Google's indexing systems from an Android mobile device, thus freeing their engineers from needing to carry a laptop computer.

After launching the Mobile Dashboard, a menu is displayed from which a user can choose which indexing system performance graphs they would like to view. Users can also choose which time periods of data they would like to see.

Users can pan and zoom on graphs to monitor various indexing system variables. Users can highlight any specific variable, which makes it stand out in the time series graph.

The Indexing System Mobile Dashboard serializes data using Google Protocol Buffers for transfer between the phone and server. The server and Android are programmed in the Java programming language.

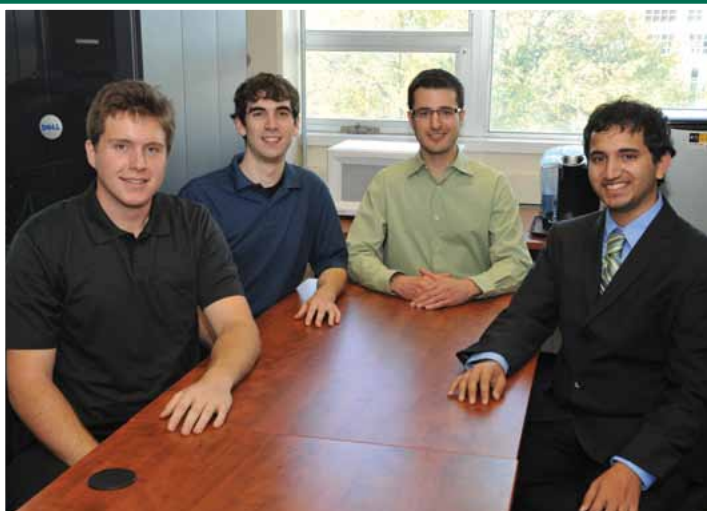

## Michigan State University

*Team Members* (left to right)

**Mike Platt**  
Monroe, Michigan

**Jason Harris**  
Northville, Michigan

**Anthony Talerico**  
Farmington Hills, Michigan

**Karthik Balasubramanian**  
Bangalore, India

## Google

*Project Sponsors*

**Andy Kreling**  
Mountain View, California

**Hal Marz**  
Mountain View, California

# Meijer IT ePager System

**M**eijer is a family owned chain of supercenters committed to providing quality food and products to its customers with over 190 stores throughout the Midwest, including Michigan.

In order to provide the best service possible for their customers, Meijer must keep each of these stores up and running 24 hours a day. To do so, system emergencies must be handled efficiently and effectively.

Our IT ePager System is designed to notify the appropriate Meijer associates quickly in the event of a system emergency. Associates at Meijer can quickly contact each other in case of power outages, pricing calculations, recalls or other important tasks that require immediate attention. Messages can be sent to multiple employees and even to entire departments.

Users of the IT ePager System can send messages to mobile phones, email or pagers. An individual user can specify the mode of communication with which they want to be paged.

The IT ePager System features a message template creation option, which enables administrative users to create and save a message template for future use. Users of the system load these pre-defined templates and need only fill in a few key variable fields before sending a message.

Our IT ePager System is web-based, written in C# and ASP.NET. Microsoft SQL Server 2008 is used for the database backend.

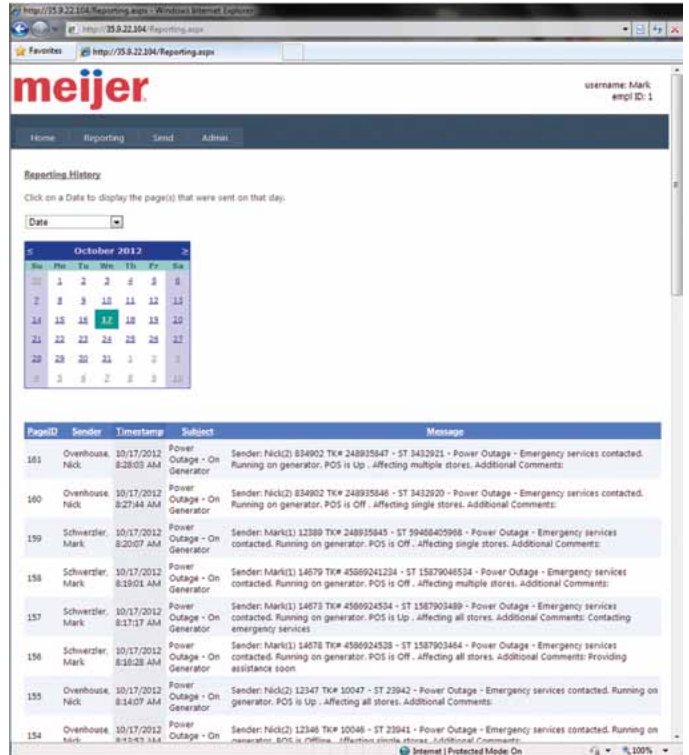

**Michigan State University**  
*Team Members* (left to right)

**Mike Sanburn**  
Mattawan, Michigan

**David Oeffner**  
Brighton, Michigan

**Mark Schwerzler**  
Troy, Michigan

**Nick Ovenhouse**  
DeWitt, Michigan

**Meijer**  
*Project Sponsors*

**Bruce Abernethy**  
Grand Rapids, Michigan

**Alan Baldrige**  
Grand Rapids, Michigan

**Todd Castor**  
Grand Rapids, Michigan

**Rosemary Wheatley**  
Grand Rapids, Michigan

# Mozilla Corporation Reader Mode for Desktop Firefox

Mozilla Firefox is a free, open source web browser that brings a multitude of new and innovative functionalities to both its mobile and desktop clients.

Over the years, websites have become more cluttered with ads and other miscellaneous content that distracts the user from the main content of interest. Some browsers have implemented a reader mode, which loads a new view of a page, with all extraneous content removed. Most of these are plugins that must be downloaded and installed separately from the browser.

Produced with guidance from Mozilla Developers, our Reader Mode for Desktop Firefox provides a built-in reader mode for the desktop version of Firefox.

Reader mode can be enabled for a site by clicking the easy to find button in the address bar. When Reader mode is activated, the current page is replaced with a de-cluttered version of itself. A preferences menu allows the user to change the font, font color, font size and various other attributes of the page.

The Reader Mode button is written in XUL. The Reader Mode functionality is implemented with JavaScript and the Readability.com algorithm. The Reader mode page and general styling are done with CSS and HTML.

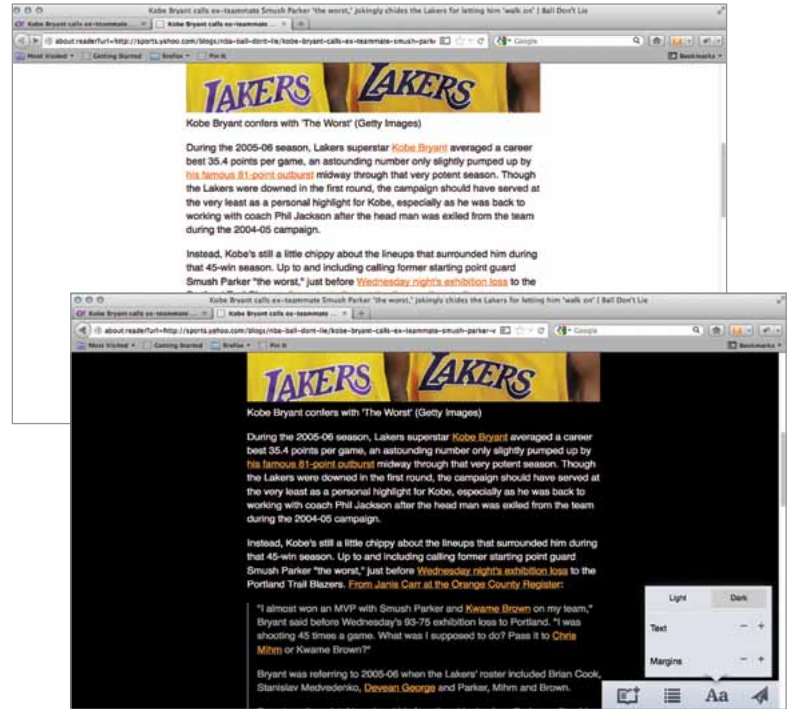

## Michigan State University Team Members (left to right)

**Michael Anderson**  
Olathe, Kansas

**Matthew Vorce**  
Fowlerville, Michigan

**Chelsea Carr**  
Farmington Hills, Michigan

**Kevin Woodward**  
Midland, Michigan

## Mozilla Project Sponsors

**Lucas Rocha**  
Beckenham, Great Britain

**Kimber Schegelmilch**  
San Francisco, California

**Jared Wein**  
Mountain View, California

# Quicken Loans

## Secure Note Taking and Collaboration Tools

Quicken Loans is a financial institution headquartered in Detroit, Michigan. Founded in 1985, Quicken Loans specializes in mortgage lending and financing.

Quicken Loans currently uses third party collaboration tools to store notes on the Internet so they can be easily accessible to other team members. Storing these notes on servers outside of Quicken Loans creates a potential security issue since the notes can contain sensitive customer information.

Designed in collaboration with our clients from Quicken Loans, our Secure Note Taking and Collaboration Tools provide a single unified location that stores all of the notes on Quicken Loans' internal computer servers.

After logging in, users can create rich text notes or freehand drawing notes. Users can save attachments to their notes and upload photos to free draw notes and draw on them. Users can do text-based searches for notes.

Quicken Loans teams can collaborate by organizing and sharing groups of notes, which are accessible only to other members of the team.

Our Secure Note Taking and Collaboration Tools run in any modern desktop web browser. It is also compatible with iPhones, iPads and Android mobile devices.

Our system is written in HTML5 and JavaScript with CSS3 styling. The underlying database is Microsoft SQL Server and the backend API is written in PHP.

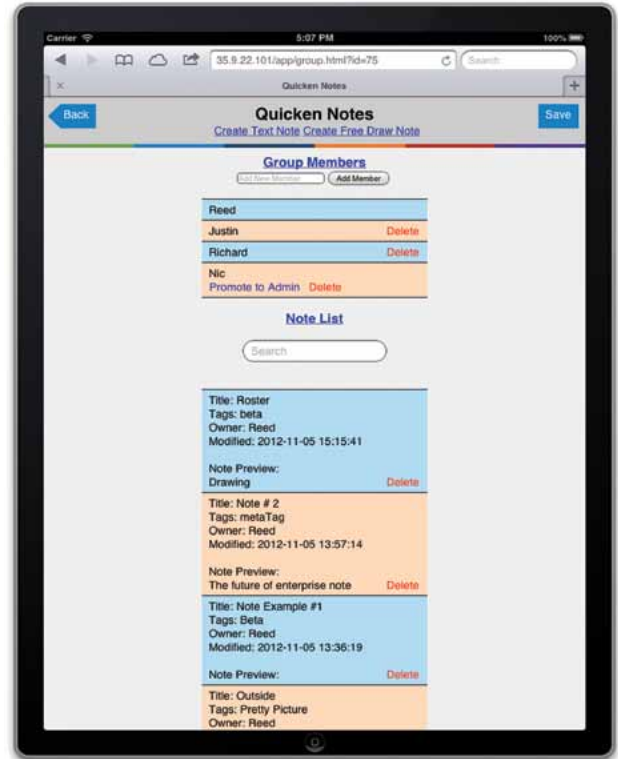

**Quicken Loans®**  
Engineered to Amaze®



**Michigan State University**  
*Team Members* (left to right)

**Richard Hofmeister**  
DeWitt, Michigan

**Justin Mrkva**  
Toledo, Ohio

**Nicholas Speeter**  
Kalamazoo, Michigan

**Reed Fielstra**  
Lake Orion, Michigan

**Quicken Loans**  
*Project Sponsors*

**John Carr**  
Detroit, Michigan

**Jamie Hamilton**  
Detroit, Michigan

**Patrick Hartford**  
Detroit, Michigan

**Linglong He**  
Detroit, Michigan

**Christina Mathes**  
Detroit, Michigan

**Bill Parker**  
Detroit, Michigan

# Spectrum Health Systems Medication Shortages Dashboard

Spectrum Health is a health care organization operating in Western Michigan, with its headquarters located in Grand Rapids. The non-profit organization aims to improve the health of the communities in which they operate.

To work effectively, Spectrum Health pharmacists need to be able to visualize and analyze medication shortages in order to make educated decisions on how to manage them. Our Medication Shortages Dashboard enables pharmacists to manage and deal with medication shortages easily and effectively.

The Medication Shortages Dashboard provides pharmacists with an at-a-glance overview of current national drug shortages. The pharmacists can rate the impact of each shortage on their hospital, and collaborate with other pharmacists in order to determine the best course of action.

Each pharmacist can create and maintain a watchlist of drugs, allowing the pharmacist to be quickly notified about status changes on those drugs.

Information about medication shortages is pulled in real time from the Food and Drug Administration (FDA) and the American Society of Hospital Pharmacists (ASHP). The data is molded into a format that is easy to process, and is displayed to the user in a clean, color-coded interface.

The dashboard is built using Ruby on Rails, HTML/CSS, and JavaScript.

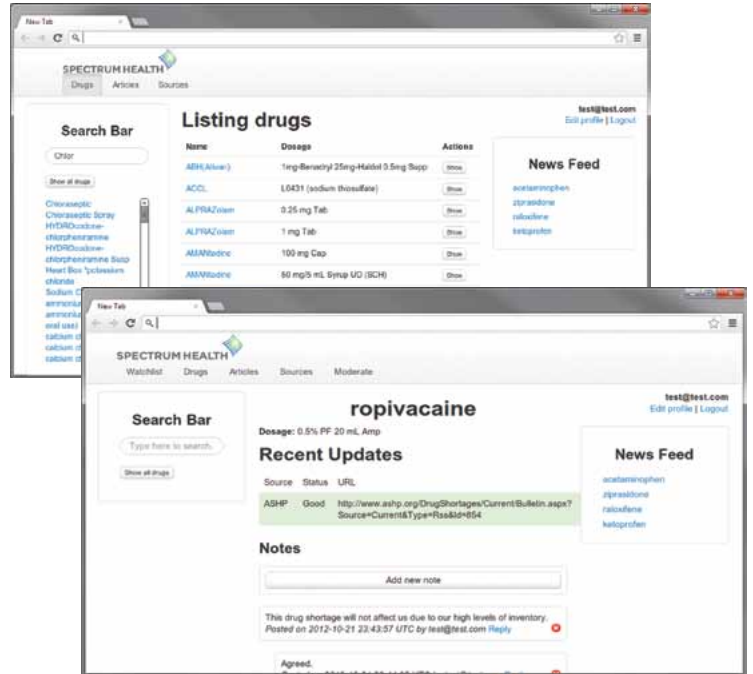

## Michigan State University Team Members (left to right)

- Grayson Wright**  
Newtown, Pennsylvania
- Eric Dostie**  
Commerce Township, Michigan
- Aaron Cosentino**  
Lake Orion, Michigan
- Ramata Koumare**  
Bamako, Mali

## Spectrum Health Project Sponsors

- Hollie Blagg**  
Grand Rapids, Michigan
- Mary Delrue**  
Grand Rapids, Michigan
- Ted Droski**  
Grand Rapids, Michigan
- Ryan Foster**  
Grand Rapids, Michigan
- Jane Gietzen**  
Grand Rapids, Michigan
- Mary Nader**  
Grand Rapid, Michigan
- Patrick O'Hare**  
Grand Rapids, Michigan
- Michael A. Rosencrance**  
Grand Rapids, Michigan
- Joel West**  
Grand Rapids, Michigan



# TechSmith Snagit Power Tools

TechSmith is a software development company based in Okemos, Michigan that focuses primarily on the creation of screencasting tools that allow users to capture or record their computer screen. Their products, such as Camtasia, Snagit, and Jing, are used all over the world by large corporations, small businesses, educators and individuals.

Snagit, TechSmith's most popular and best-selling product, is an application that allows users to quickly and conveniently capture their computer screen and annotate the results in a variety of ways.

Our Snagit Power Tools are a suite of four applications that extend Snagit's functionality, allowing users to do potentially tedious and time-consuming tasks with relative ease.

The Screen Recording DVR Tool schedules Snagit captures for a future time and date. The Macro Recorder Tool records macros ending in a Snagit capture.

The Social Media Stream Tool displays images from a user's Facebook account that can be edited with Snagit. The Map Maker Tool captures Google maps, which can then be edited with Snagit.

Our Snagit Power Tools are written in C#, use WPF for the interfaces and use the Snagit COM SDK to communicate with Snagit.

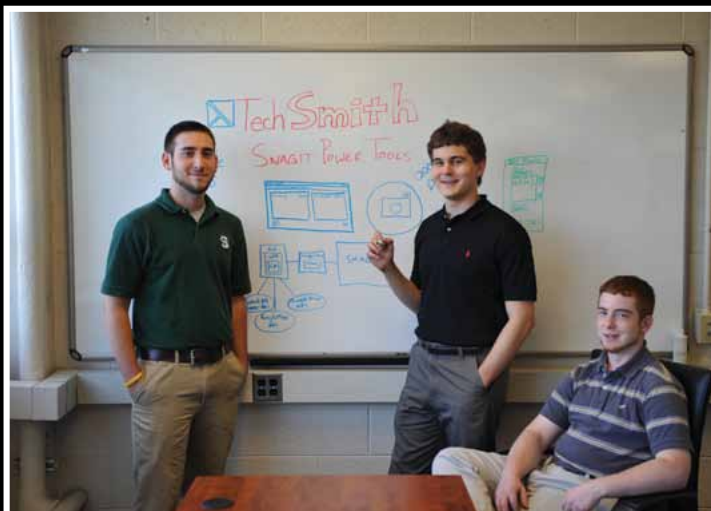
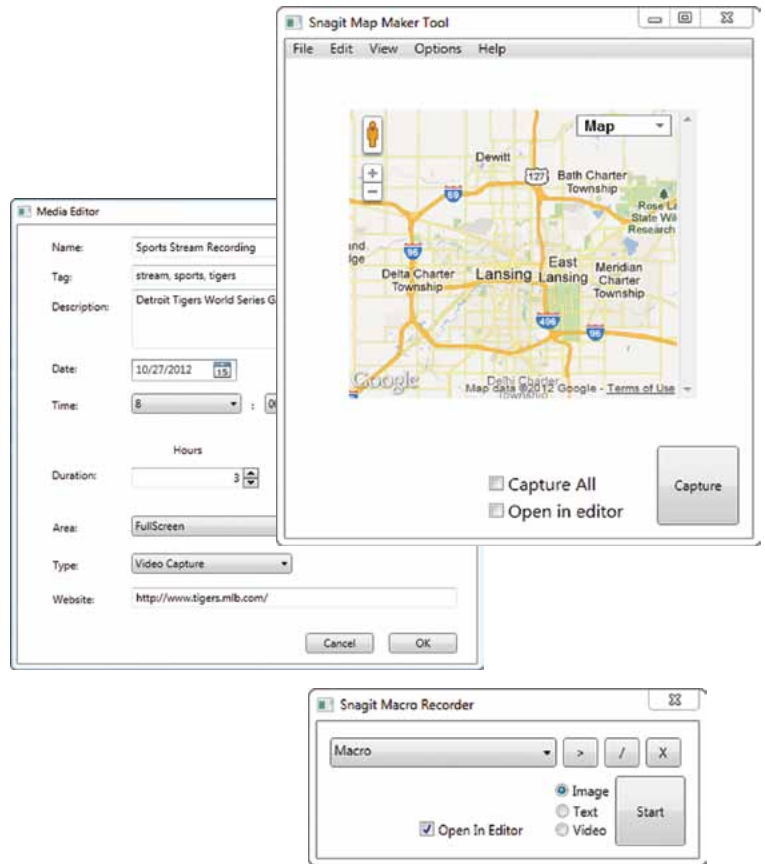

**Michigan State University**  
*Team Members* (left to right)

**Benjamin Blaut**  
Cincinnati, Ohio

**David Markachev**  
White Lake, Michigan

**Kyle Gosen**  
Birch Run, Michigan

**TechSmith**  
*Project Sponsors*

**Jacob Anderson**  
Okemos, Michigan

**Dean Craven**  
Okemos, Michigan

**Ryan Eash**  
Okemos, Michigan

**Bill Hamilton**  
Okemos, Michigan

**Tony Homrich**  
Okemos, Michigan

**Dave McCollom**  
Okemos, Michigan

# Urban Science

## Mobile Geography Management

Urban Science delivers maximum results in the automotive industry for OEMs (original equipment manufacturers) worldwide through optimization software and scientific analysis. Their products and services enable clients to evaluate and manage their dealer networks more effectively and more efficiently.

One very important aspect of dealer network management is that of geography management, which allows OEMs to view and modify geographic territories defined by census data.

Our Mobile Geography Management application extends this concept to mobile devices, specifically the iPad, featuring touch gestures for an optimized and well-formatted display. Since dealer networks and therefore geography assignments change constantly, we provide several visual cues allowing for straightforward interactions and analysis of data.

After launching the application, the user can zoom and view geographic territories and automotive dealerships within the United States in one continuous motion. The user can select and edit any geographic territory with the touch of a finger.

Our application provides a mobile solution for managing geographic territories and assists in achieving maximal results for OEM dealer network evaluation and management.

The Mobile Geography Management application is written using JavaScript, HTML5, and PHP. Geographic data is stored using an SQL Server 2008 database.



### Michigan State University

*Team Members* (left to right)

**Forrest Young**

Bay City, Michigan

**Dominykas Siaudvytis**

Saline, Michigan

**Brandon Kienle**

Clinton Township, Michigan

**Jake Wesorick**

Rockford, Michigan

### Urban Science

*Project Sponsors*

**Matt Bejin**

Detroit, Michigan

**Michael DeRiso**

Detroit, Michigan

**Greg Davidson**

Detroit, Michigan

**Steve Kansa**

Detroit, Michigan

**Linda Koeppe**

Detroit, Michigan

**Shannon Muldowney**

Detroit, Michigan

# Whirlpool Connected Appliances Analytics Dashboard

**W**hirlpool Corporation, headquartered in Benton Harbor, Michigan, is a global leader in appliance manufacturing across all major categories.

As a constant innovator in the field, Whirlpool is now offering “Connected Appliances” that give greater control to customers and greater insight into how Whirlpool products are used.

Connected Appliances provide a large amount of information to Whirlpool. Our Connected Appliances Analytics Dashboard acquires this data, presenting it in a user-friendly format.

Whirlpool customer service representatives can use this system to aid a customer in identifying their online account ID by using minimal information to search customer records. Representatives can view the current state of a customer’s appliances and assist in their use or recommend future products.

To guide future strategy in research, development, and marketing, the Connected Appliances Analytics Dashboard provides an overview for broad categories of appliances, such as dishwashers or refrigerators. In addition to these dashboards, Whirlpool users can create custom queries of the data to gain understanding into very specific customer usage and needs.

Our Connected Appliances Analytics Dashboard uses a variety of technologies, including Java, MySQL, PHP, CSS, jQuery, and JavaScript.

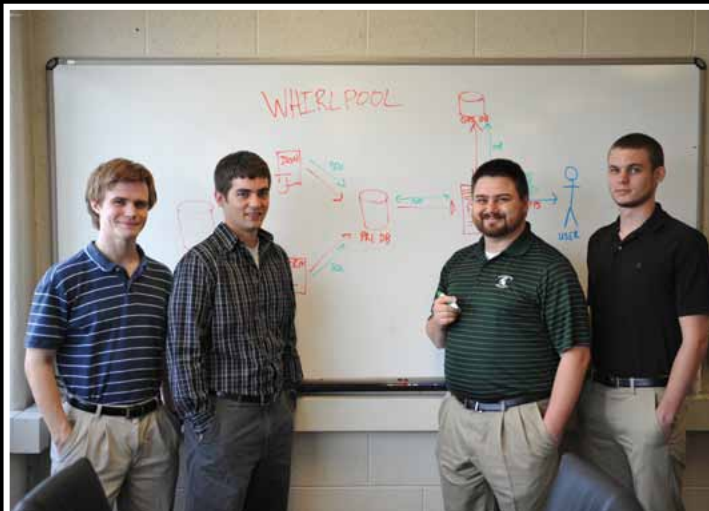
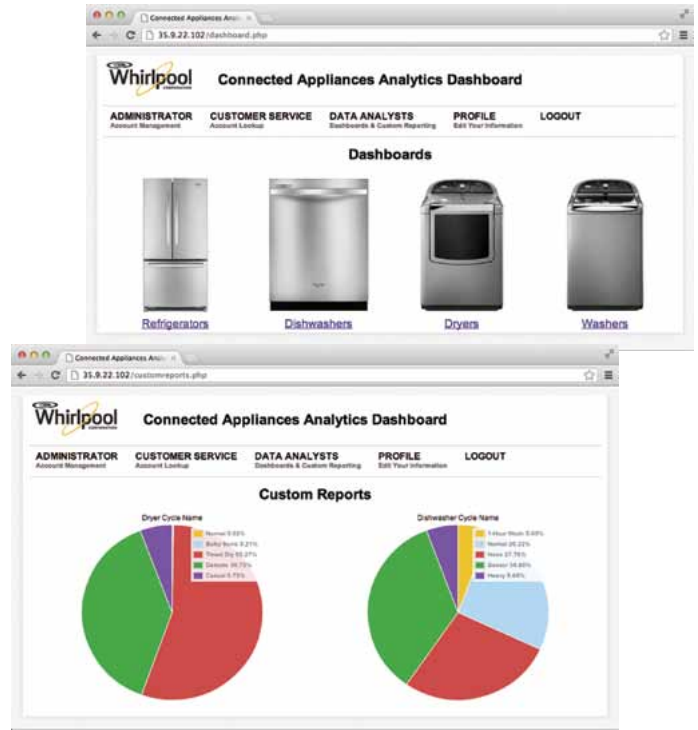

**Michigan State University**  
*Team Members* (left to right)

**Zachary Taylor**  
Mt. Pleasant, Michigan

**Joseph Tuohy**  
Dearborn, Michigan

**James Solce**  
Cadillac, Michigan

**Derrick Neier**  
Bay City, Michigan

**Whirlpool**  
*Project Sponsors*

**Fred Bellio**  
Benton Harbor, Michigan

**Reagan Craven**  
Benton Harbor, Michigan

**Heidi Groulx**  
Benton Harbor, Michigan

**Vince Ireland**  
Benton Harbor, Michigan

**Michael Jakeway**  
Benton Harbor, Michigan

**Carl Wendtland**  
Benton Harbor, Michigan

# Design Day Awards

CSE 498, Collaborative Design, is the senior capstone course for students majoring in computer science. Teams of students design, develop, and deliver a significant software system for corporate clients. The CSE capstone teams compete for four prestigious awards. The winners are selected on Design Day by a panel of distinguished judges.

## Auto-Owners Exposition Award



CSE 498 capstone teams present their projects on Design Day in a variety of ways. Teams create and set up an exhibit where they demonstrate their software systems and answer questions from Design Day attendees. Each team plays their project videos and answers questions for a panel of judges.

The CSE capstone team with the best overall Design Day performance is honored with the Auto-Owners Exposition Award, which is sponsored by Auto-Owners Insurance Company of Lansing, Michigan.

Team Mozilla  
In-Content Preferences for Firefox



Joe Chen, Jon Rietveld, Owen Carpenter, Devan Sayles  
Presented by Scott Lake of Auto-Owners Insurance

## Chrysler Praxis Award



One of the hallmarks of CSE 498 capstone projects is that of praxis, the process of putting theoretical knowledge into practice. Teams apply a wide variety of information technologies to produce solutions to complex problems in areas such as business, engineering, computing, and science.

The CSE capstone team that engineers the software system that is the most technically challenging is recognized with the Chrysler Praxis Award, which is sponsored by Chrysler LLC of Auburn Hills, Michigan.

Team Boeing  
Design, Fly and Compete Flight Simulator



David Cornelius, Jon Moore, Brandon Overall  
Presented by Karen Wrobel of Chrysler

# Spring 2012

## Design Day Judges

Greg Davidson  
*Urban Science*

Rich Enbody  
*Michigan State University*

Adam Haas  
*Ford*

Louise Hemond-Wilson  
*IBM*

Brian Loomis  
*Microsoft*

Patrick O'Hare  
*Spectrum Health*

Kevin Ohl  
*Michigan State University*

Marty Strickler  
*Rose Packing Company*

Karen Wrobel  
*Chrysler*

## TechSmith Screencast Award



Each CSE 498 capstone team produces a video that describes and demonstrates their software product. Starting with a storyboard and a script, teams use Camtasia Studio to synthesize screen recordings, video, audio and other multimedia to produce their project videos.

And the TechSmith Screencast Award goes to... the CSE capstone team with the best project video. The award is sponsored by the creators of Camtasia Studio, TechSmith of Okemos, Michigan.

Team Plex Systems  
HTML5-Based WYSIWYG Label Designer



Andrew Melfi, Michele Winsky, Matt Duffy  
Presented by Dean Craven of TechSmith

## Urban Science Sigma Award



The CSE 498 experience represents the capstone of the educational career of each computer science major. An intense semester of teamwork produces impressive deliverables that include a formal technical specification, software, documentation, user manuals, a video, a team web site, and Design Day participation. The resulting sum, the capstone experience, is much greater than the parts.

The capstone team that delivers the best overall capstone experience is recognized with the Urban Science Sigma Award, which is sponsored by Urban Science of Detroit, Michigan.

Team GE Aviation  
Mobile Avionics Weather



Drew Space, Mike Dunn, Eric Cook  
Presented by Matt Bejin and Greg Davidson of Urban Science

# Auto-Owners Insurance

PROUD SPONSORS OF

## THE MSU COLLEGE OF ENGINEERING DESIGN DAY 2012

FOUNDED AND BASED IN MID-MICHIGAN.  
RANKED FORTUNE 500 SINCE 2002.  
EMPLOYER TO SOME OF MSU'S FINEST.



*Auto-Owners Insurance*



# **WANTED: Humans**

**(Amazing ones, please.)**

We want your new ideas, your fresh takes, your quirky view of the world, your unique youness that makes you you.

**You get it? WE WANT YOU!**

**Quicken<sup>®</sup> Loans**  
Engineered to Amaze<sup>SM</sup>

**[800] 411.JOBS**

**QuickenLoansCareers.com**

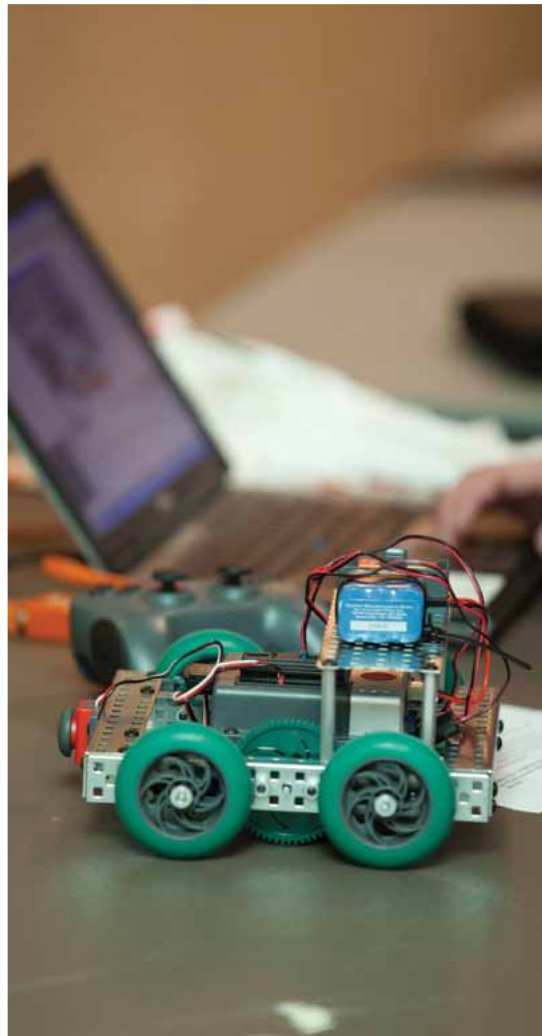





## The Capstone Projects

**Dr. Michael Shanblatt**  
Professor of Electrical &  
Computer Engineering

### Presentation Schedule – Heritage Room, Garden Level

Time	Team Sponsor	Project Title
8:00 a.m.	Air Force Research Laboratory	Equipment Rack Active Cooling System
8:25 a.m.	Air Force Research Laboratory	Moving Human Electromagnetic Scattering Simulator
8:50 a.m.	MSU Resource Center for Persons with Disabilities	Haptic User Interface
9:15 a.m.	MSU Resource Center for Persons With Disabilities	Branden's Detented Joystick
9:40 a.m.	Break	
10:00 a.m.	ArcelorMittal	Load Metering and Transmission
10:25 a.m.	Texas Instruments	Electrocardiograph Demonstration Board
10:50 a.m.	Instrumented Sensor Technology Inc.	User Settable G-Switch
11:15 a.m.	The Advanced Integrated Microsystems (AIM) Laboratory	GUIMoo: Graphical User Interface for Moo RFID Sensor Platforms
11:40 a.m.	Texas Instruments	Robotic Transportation Vehicle

## ECE 480 Senior Design

ECE 480 is required of all electrical engineering or computer engineering majors at MSU. It prepares students for the workplace, or for graduate school, including:

- Putting into practice the technical skills learned in the classroom, on industrially sponsored team projects, under faculty guidance, doing open-ended design, giving them experience in teamwork, project management, product life cycle management, legal, intellectual property, accommodation issues and entrepreneurship.
- Polishing their communication skills – individual and team – on proposals, reports, resumes, evaluations, posters, web pages, and oral presentations.
- Requiring each student to complete four individual hardware/software laboratory assignments.

Team sponsors are local and national, including MSU Resource Center for Persons with Disabilities, Texas Instruments, Air Force Research Laboratory, ArcelorMittal, Instrumented Sensor Technology, and MSU Technologies

# Air Force Research Laboratory Equipment Rack Active Cooling System

The United States Air Force has tasked our team to design a cooling system that effectively and efficiently reduces the ambient temperature of an enclosure that houses critical electronic equipment. The Air Force's electronic equipment is deployed in a range of missions that support military, civilian, and humanitarian endeavors. The design of the cooling system must have the capability to have full functionality in high temperature and humid areas that have the potential to exceed 125°F.

Our capstone project design utilizes the concept of liquid cooling to successfully dissipate 2000 watts of heat produced by the electrical equipment. Our design has efficiently regulated the temperature of the E.R.A.C.S. between the design specification range of 59°F-113°F. For versatility, the cooling system has the ability to acquire power from three different sources; 12 VDC, 24 VDC, and 110 VAC. To avoid any latent threats that may contaminate the electronic equipment or surrounding environment, the cooling system is air tight and does not permit any exchange to the exterior air in the surrounding environment.

Our design is composed of a cooling system enclosure that is connected by insulated tubing to the electronic equipment enclosure. Fans are located inside the tubing to create a minimum flow rate to circulate cold air into the electronic enclosure and hot air into the cooling system thus essentially recycling the air throughout the system.

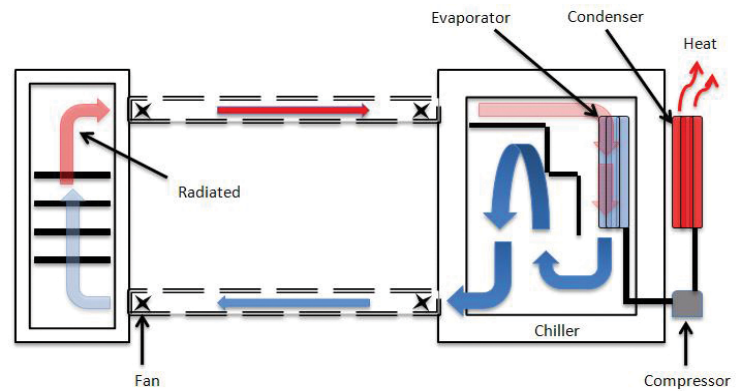

## Michigan State University

*Team Members* (left to right)

**Cerronne Cathey**  
Hamtramck, MI

**Calan Underwood**  
Warren, MI

**Mason Pike**  
Howell, MI

**Michael Robell**  
Dearborn Heights, MI

**Kilian Davis**  
Royal Oak, MI

## Air Force

*Project Sponsor*

**Ben Bosma**  
Wright Patterson AFB, Ohio

# Air Force Research Laboratory Human Electromagnetic Scattering Simulator

The Air Force Research Laboratory (AFRL) has sponsored our team to develop a system to quickly and automatically capture human movement. The Air Force currently uses software packages to model electromagnetic scattering, which is an important component of radar technologies. These technologies have been developed for a variety of scenarios, including military reconnaissance as well as search and rescue missions. However, these packages currently require the manual input of human parameters such as arm, length, and torso size to accurately model human movement. The AFRL has asked us to collect the information required by these software platforms automatically.

We have accomplished this goal by using an ASUS Xtion in combination with a PandaBoard ES microcomputer inside of a custom enclosure. The ASUS Xtion is able to detect when a human has entered its field of vision, and the connected microcomputer can then process this data. The final design is able to communicate with an external computer over a network and can send this data to an application that initializes AFRL provided software.

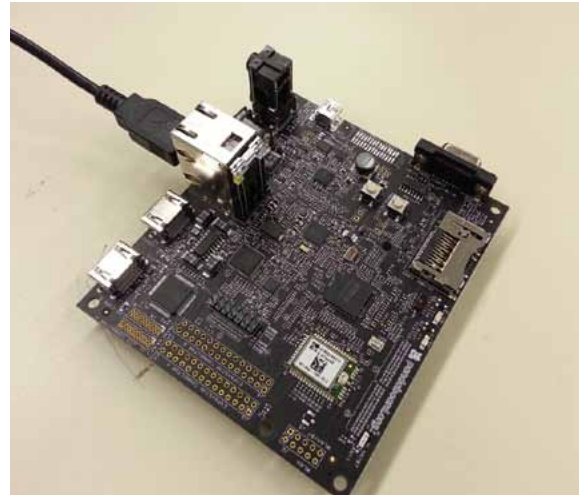

## Michigan State University

*Team Members* (left to right)

**Camden Smith**  
East Lansing, MI

**Ryan Lattrel**  
Oxford, MI

**William Juszczuk**  
Fraser, MI

**Mark Birdsall**  
Grand Ledge, MI

**Michael Lazar**  
Lowell, MI

## Air Force

*Project Sponsors*

**Dr. Analee Miranda**  
Wright Patterson AFB, Ohio

**Mr. Kenneth Schafer**  
Wright Patterson AFB, Ohio

# Resource Center for Persons with Disabilities

## Haptic User Interface

Currently visually impaired students like Jordyn, an engineering student on campus, have many methods and devices to aid in reading textbooks and navigating through computer windows in order to do homework and other assignments. However, one thing is missing for these students, a way to experience and feel images. This is essential when trying to perform homework that has graphs or other visual aids. There are products on the market that help users perform this task, such as printing embossers, pin displays, force feedback mice and several other options. Unfortunately, these products tend to fall short in at least one or two categories; they are either too costly, or they are inefficient. Devices like pin displays or embossers can cost upwards of \$10,000, and some of the devices on the market require the creation of a hard copy embossed image that must be stored and used only one time. Another example of inefficient devices are force feedback mice which have steep learning curves. For the above reasons, our group designed a refreshable haptic user interface. This is a device that induces a touch sensation, thus allowing the user to “feel” text or an image.

After speaking with Jordyn, Mr. Blosser with RCPD, and other visually impaired students on campus, our design team decided the best method for accomplishing the refreshable haptic user interface was to use a matrix of pins constructed from miniature solenoids. These are much more cost effective than braille cells and graphic displays. Additionally, in-house design and fabrication of the solenoids further reduced the cost and allowed the group to optimize the size of the solenoids to fit the project’s specific needs. Upon fabrication of the pins, a microcontroller was used to communicate with the computer and send the signal that raises the appropriate pins. The microcontroller determines which pins to raise by utilizing a computer program our group created which uploads an image, converts it to black and white, and raises the appropriate pins on our display which correspond to black pixels on the computer image. This process allows the end user to select an image which results in an almost immediate display of the image on our display pins. Overall, the group managed to provide an easy to use product which is comparable to the expensive devices currently on the market today.

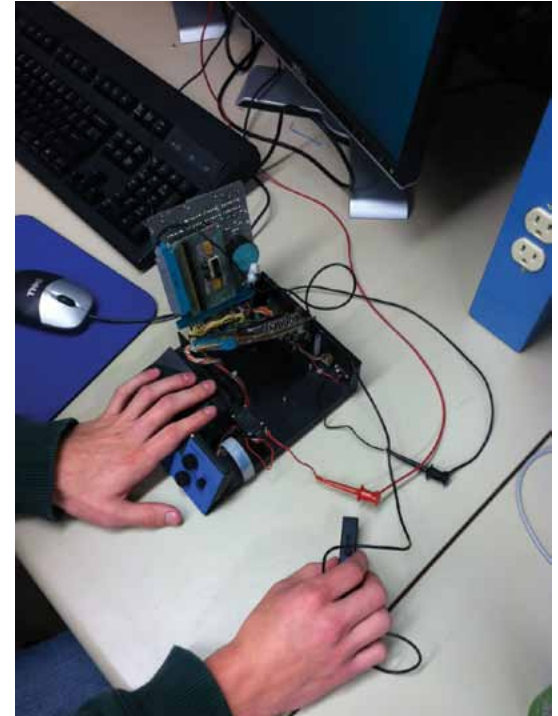

Resource Center  
for Persons with  
Disabilities



### Michigan State University

*Team Members* (left to right)

**Kyle Pulis**  
Troy, MI

**Lyle Jackson**  
Middleville, MI

**Osama En-Nasr**  
Palestine

**John Demery**  
Plymouth, MI

**Mike Thompson**  
DeWitt, MI

### RCPD at MSU

*Project Sponsor*

**Mr. Stephen Blosser**  
East Lansing, MI

# Resource Center for Persons with Disabilities

## Branden's Detented Joystick

Every year in the United States, approximately 10,000 infants are diagnosed with Cerebral Palsy (CP), a group of disorders affecting brain and nervous system functions. There are several types of CP with varying levels of symptoms, ranging anywhere from abnormal muscle contractions and loss of coordination to partial paralysis and loss of speech capabilities. While most people living with CP are able to process information efficiently, they may not have the motor skills necessary to communicate their ideas with others. It is therefore a necessity that they have assistive technology that can form a medium of communication for them.

Our Team was tasked with designing a joystick to function as an electronic device interface for individuals living with Cerebral Palsy (CP). We have developed a programmable joystick that provides local support at designated positions, valuable in controlling the involuntary muscle spasms common to those with CP. The number of positions and the strength of the stabilizing mechanism can be selected by the user through a computer interface to meet the specific needs of different CP cases. With this new design, people living with CP will now have a more efficient means of communication that is tailored to fit their specific abilities.



Resource Center  
for Persons with  
Disabilities



### Michigan State University

*Team Members* (left to right)

**Aditya Mathew**  
Calcutta, India

**Yongjiao Yu**  
Xi'an, China

**Scott Friedman**  
West Bloomfield, MI

**Nathan Hyde**  
Manchester, MI

**Peter Ossian**  
Tawas City, MI

### RCPD at MSU

*Project Sponsor*

**Mr. Stephen Blosser**  
East Lansing, MI

# ArcelorMittal S.A.

## Load Metering and Transmission

ArcelorMittal's steel operations at its facility in Burns Harbor, IN routinely require up to 100 megawatts (MW) of power usage. Due to the cost of buying electrical power and the company's limited generating capabilities, having knowledge of the total electrical power needs throughout the facility at any time is vital to economic operation.

To monitor the facility power usage ArcelorMittal has power meters measuring the power usage at each individual building throughout its facility which provide a 0 to 100 millivolt (mV) analog signal representing the measured power usage. The information from the power meters at each building then needs to be transmitted a distance of up to one mile to the facility Central Control Room where the signals are converted to a 1 to 5 volt analog signal which is read by Programmable Logic Controllers (PLC) and converted back to a value of power usage.

The problem for the team was to develop a reliable and accurate method of transmitting a power signal from the power meters at each building to the Central Control Room. The team's design solution was to use Pulse Width Modulation (PWM) as a method of signal transmission along a twisted-pair transmission line. The design consists of a PWM modulator which serves as the encoder and a PWM demodulator which serves as the decoder. PWM was chosen due to the ability of a PWM signal to hold the integrity of the transmitted information regardless of possible loss along the transmission line and its ability to be implemented well within a \$500 project budget.

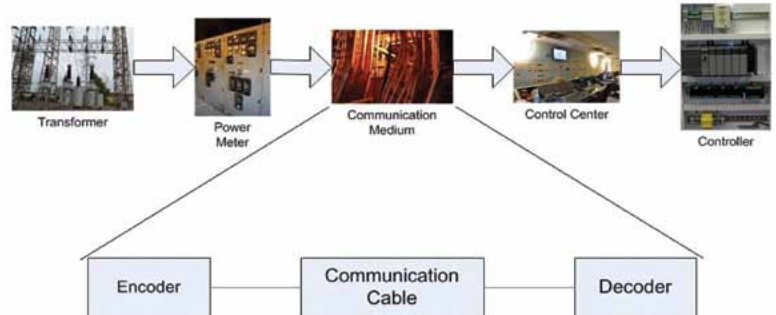

# ArcelorMittal



### Michigan State University

*Team Members* (left to right)

**Patrick Powers**  
Lansing, Michigan

**Alexander Gollin**  
Munger, Michigan

**Kenneth Young**  
Rockford, Michigan

**Nan Xia**  
Xinjiang, China

**Cheng Zhang**  
Shanghai, China

### ArcelorMittal S.A.

*Project Sponsors*

**Thomas Whittaker**  
Burns Harbor, IN

**Eduardo Ferragini**  
Burns Harbor, IN

# Texas Instruments Electrocardiograph Demonstration Board

Electrocardiograph (ECG) boards are commonly used in ECG machines, also known as EKG machines, to analyze electrical signals produced by the heart. They are found in research labs and hospitals where they are used to research effects of drugs and medical devices on the heart, as well as monitor the health of patients. Even with how widely used ECG boards are, Texas Instruments (TI) has found an increase in client demand for ECG technology. To demonstrate the supremacy of their chips in ECG applications, TI tasked Design Team 6 with creating a new demonstration board capable of enhancing customer interest in Texas Instrument's products.

Design Team 6 designed, fabricated, assembled and enhanced an ECG demonstration board for Texas Instruments. The board features current TI chips, such as the INA333, in addition to quality, efficient routing designed to TI standards. This board is capable of receiving input from a human source, processing the received data and displaying the resulting information on an LCD screen in a user friendly manner. This ECG board can be used to drive customer interest in TI chips and engineering solutions pertaining to electrocardiograph technology.

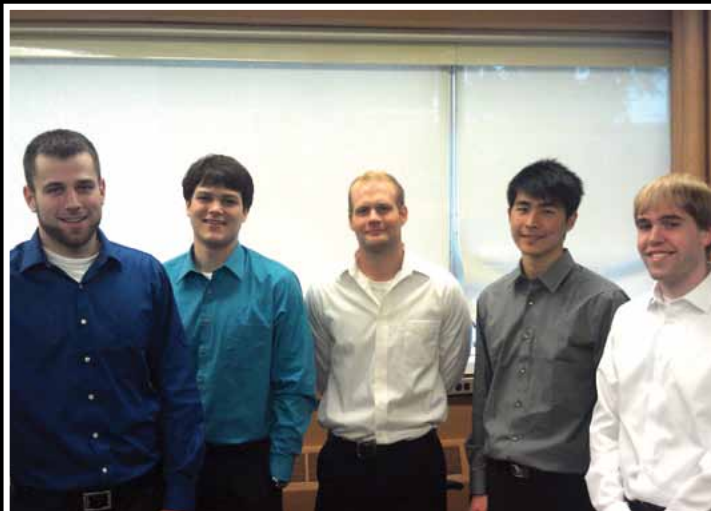

**Michigan State University**  
*Team Members* (left to right)

**Derek Brower**  
Rockford, MI

**Matt Affeldt**  
Warren, MI

**Phil Jaworski**  
Northville, MI

**Jung-Chun Lu**  
Taichung, Taiwan

**Alex Volinski**  
Harrison Township, MI

**Texas Instruments**  
*Project Sponsor*

**Mr. Pete Semig**  
Novi, Michigan

# Instrumented Sensor Technology Inc. User Settable G-Switch

Vibrations and vigorous movement can be very damaging to commercial and industrial machines. These changes in acceleration are scientifically called g-force. A common example of a damaging event is when a washing machine becomes heavily unbalanced. If unbalanced for a long period of time, serious damage can occur.

Our G-Switch design would be able to read the G-levels occurring in real time, trip a relay, and ultimately cut power to the machine before this damage becomes permanent. The main components of the G-Switch consist of an accelerometer, connected to a programmable microprocessor, which is then outputted to two relays. The accelerometer's main task is to be able to sense the present G-level and send digital signals to the microprocessor. The microprocessor then compares that digital signal from the accelerometer to the binary information from a 4 pin DIP Switch and decides whether to trip the relays.

The DIP switch gives the user the ability to select between 8 peak or 8 RMS G-level trip settings giving them the freedom and flexibility of multiple settings. Our final design of the G-Switch offers a low-cost and portable safety precaution from excessive G-levels for many different types of machinery.

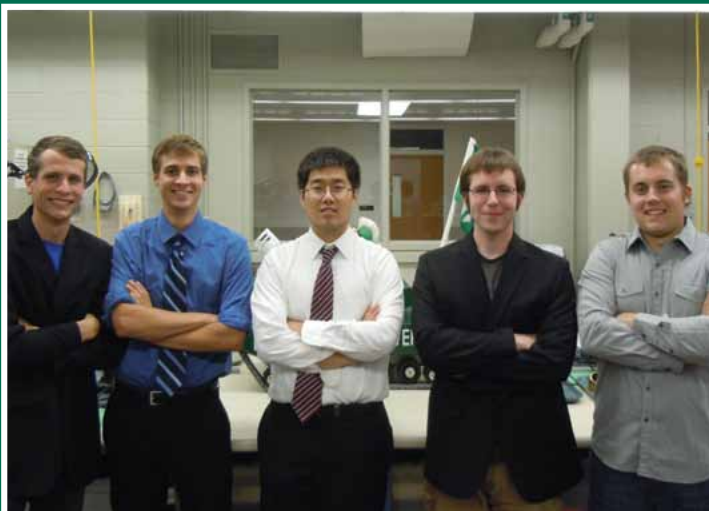
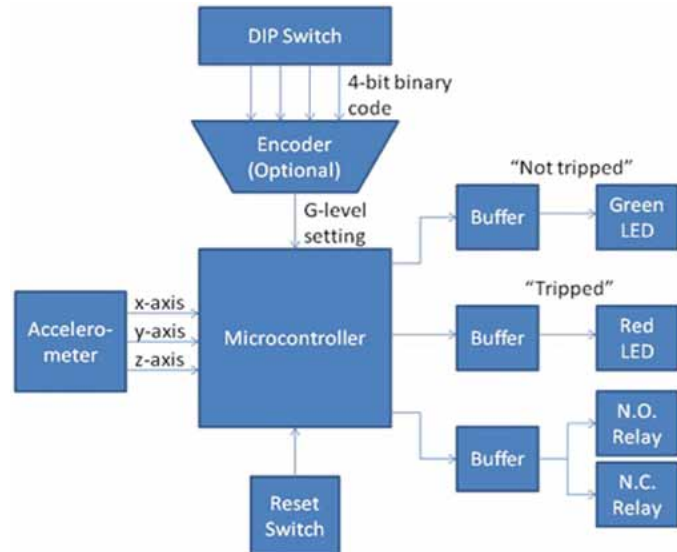

## Michigan State University

Team Members (left to right)

**Sean VanHaren**  
Grand Rapids, Michigan

**Frank Doherty**  
Mt. Pleasant, Michigan

**Xiao Xu**  
Okemos, Michigan

**Tom Larter**  
Clinton Township, Michigan

**DJ Eaton**  
Portage, Michigan

## IST, Inc.

Project Sponsor

**Greg Hoshal**  
Okemos, MI



# MSU Technologies

## GUIMoo: GUI for Moo RFID Sensor Platforms

The Advanced Integrated Microsystems (AIM) Laboratory at Michigan State University is researching methods to develop a system that will allow autonomous monitoring of the health of infrastructures (such as transportation systems, government and commercial facilities) in order to more efficiently assign maintenance priorities. One method being researched is the implementation of Moo WISPs, low-power microcontrollers that use Radio Frequency Identification (RFID) signals as a power source and communication medium, into common foundation materials, such as concrete. These Moo WISPs are then used to record long-term infrastructure health measurements and wirelessly transmit the data to a user friendly program during queries. Antennas and readers are used to read in and transmit data from the sensors to a user interface (UI) on a computer. Design team 8 was assigned to develop a UI that can be used to display the location of a Moo WISP, with respect to the antennas, and the data stored in it.

The team developed a web-based graphical user interface (GUI), named GUIMoo, to display the distance and orientation of Moo RFIDs with respect to the antennas connected to the readers. GUIMoo stands for Graphical User Interface for Moo. It uses three-dimensional (3D) technology to display the orientation and distance of the Moo RFIDs, as well as the information stored in them.



MICHIGAN STATE  
UNIVERSITY

MSU Technologies

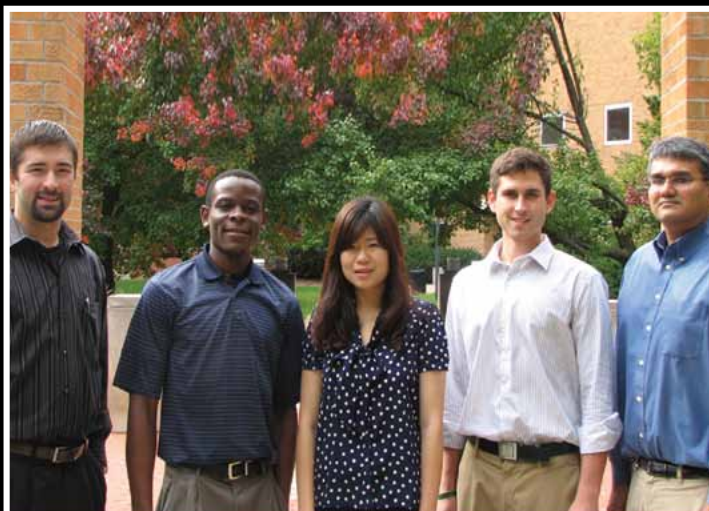

### Michigan State University

*Team Members* (left to right)

**Erik Butterfield**  
Clarkston, MI

**Tabula Mbala-Nkanga**  
Libreville, Gabon

**Menglin Li**  
Wuhan, China

**Samuel Richter**  
Troy, MI

**Daniel Perez**  
Williamston, MI

### MSU Technologies

*Project Sponsor*

**Shantanu Chakrabartty**  
East Lansing, MI

# Texas Instruments Robotic Transportation Vehicle

Team 9 has been assigned a project from Texas Instruments involving the assembly and design of a communication network that interfaces between a radio frequency controller, a central processor, two microcontrollers, and two motors. The device will be used to control a robotic transportation vehicle for Texas Instruments' Motor Instrumentation Lab.

The wireless network is composed of hardware and software supplied by Texas Instruments. The device is battery powered and is built on a 4-wheeled platform with electric brushless DC motors driving 2 of the 4 platform wheels. These motors are controlled by the two programmable microcontrollers embedded in the device. The Central Processor code development was done using the IDE CodeComposerStudio version (CCS.v5) with the C programming language, while the motor function controls were programmed using the IDE ControlSuite. In order to wirelessly control the signal input and output of the device interface, Team 9 used the RF function of a Chronos watch. This enables a user to send a signal to the central processor that communicates to the microcontrollers thus allowing manual direction and speed control.

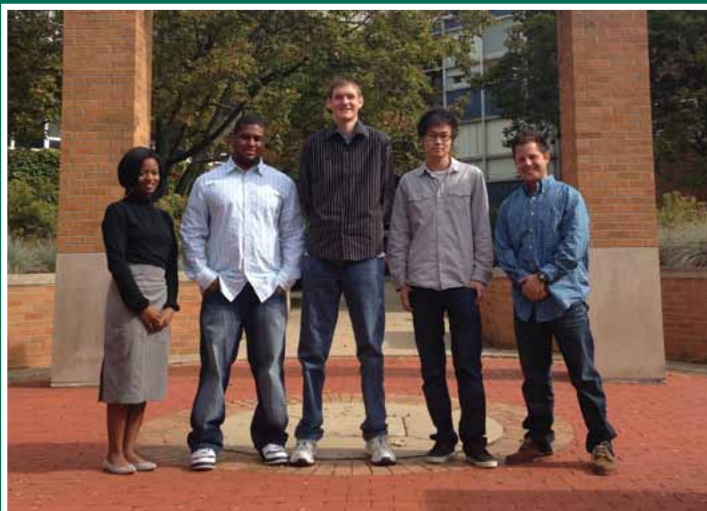
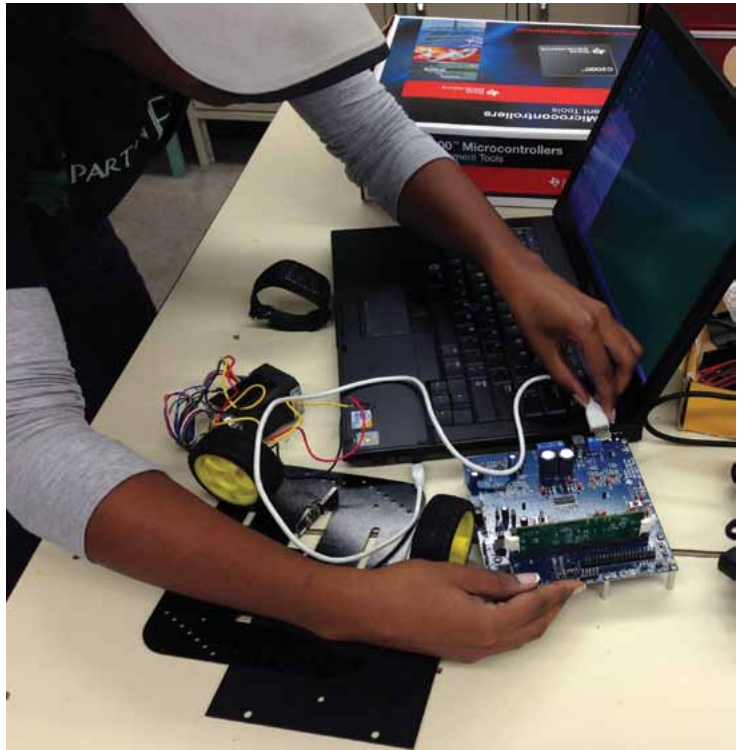

## Michigan State University

*Team Members* (left to right)

**Grace Jones**  
Washington, DC

**Stevie Baldwin**  
Three Rivers, Michigan

**Alex Koschmann**  
Waterford, Michigan

**Haotian Cai**  
Harbin, China

**Timur Yaprak**  
Ann Arbor, MI

## Texas Instruments

*Project Sponsor*

**Tim Adcock**  
Dallas, Texas

# Design Day Awards Spring 2012

---

## Electrical & Computer Engineering Prism VentureWorks Prize & Winners, Spring 2012

The Prism VentureWorks Prizes (\$1,500, \$1,000, and \$500, respectively) are awarded each semester to the most outstanding teams in the Electrical and Computer Engineering Senior Capstone Design Course, as judged by a panel of engineers from industry. A team with members from both ECE and another engineering major (mechanical engineering, for example) is also eligible, if the team's project is administered through ECE 480. The prizes are sponsored by Prism VentureWorks, a Boston-based venture capital firm, and Mr. William Seifert, an ECE alumnus, who is a partner in that firm. The faculty and students of Electrical and Computer Engineering are very grateful for this generous support.

---

### Prism VentureWorks First Prize: Robotic Hyena Project: Animatronic Hyena for Field Research in Kenya

left to right:  
Dr. Michael Shanblatt, Ross Schwarz, Leon Voskov, Kasra Dabiran,  
Phil Zanotti, Eric Mitchell



### Prism VentureWorks Second Prize: Texas Instrument: Wireless Sensing System for Intelligent Concrete Curing

left to right:  
Dr. Michael Shanblatt, Yanqing Li, Kevin Gladstone,  
ChaiYong Lim, Jon Sangregario



### Prism VentureWorks Third Prize: ArcelorMittal: Blast Furnace Moisture Measurement Device

left to right:  
Dr. Michael Shanblatt, Matthew Voog, Yuan Liang, Jacob Zells





## Take MSUFCU With You

When you graduate, you don't have to close your account. Wherever your new career opportunities take you—take MSU Federal Credit Union with you!

**Service Centers and shared branches** are a network of credit union locations where you can access your MSUFCU account for FREE and are available nationwide! Find a location near you at [www.cuservicecenter.com](http://www.cuservicecenter.com).

**ComputerLine, Mobile Banking, and MSUFCU's Mobile App** allow you to perform over 40 transactions anywhere, anytime as long as you have internet access. Plus, Green on the Go® mobile banking and MSUFCU's Mobile app for Apple and Android™ phones provides fast and secure account access anytime, anywhere for FREE\* from your internet-compatible mobile phone.

**eDeposit** allows you to electronically deposit checks or apply them to your loans through ComputerLine or the Mobile apps.

**FREE ATMs** There are over 100 surcharge-free MSUFCU ATMs in the Greater Lansing area and over 30,000 surcharge-free CO-OP Network ATMs located nationwide where you can access your MSUFCU account, make transfers, and more.

**Extended Hours** MSUFCU makes it easy to get in touch with us by offering extended hours online and over the phone. Speak with a member service specialist Monday-Friday from 7:00 a.m. to 9:00 p.m. and Saturdays from 9:00 a.m. to 3:00 p.m. Or, contact us online via Instant Chat Monday-Friday from 8:00 a.m. to 7:00 p.m. and Saturdays from 9:00 a.m. to 3:00 p.m.



Carry your Spartan Pride!

517-333-2424 • 800-678-4968 • [www.msufcu.org](http://www.msufcu.org)

\* Although MSUFCU does not charge any fees for Green on the Go® mobile banking and the MSUFCU Mobile app, service, connectivity, access, or usage fees from your wireless provider may still apply.







**ME 371  
Mechanical Design I**

**Farhang Pourboghrat  
Professor of Mechanical  
Engineering**

**Brian Thompson  
Professor of Mechanical  
Engineering**

**Thrills for Pre-collegiates: Mechanisms that fascinate, captivate, stimulate and entice**

Teams of students were required to design and manufacture mechanisms that would thrill an audience of pre-collegiates. The only constraints imposed upon the assignment were that each mechanism must incorporate at least one linkage, one gear set and one cam-follower combination. These engineering marvels will be displayed along with a complementary poster explaining the subtleties of each mechanism, and each device will be demonstrated to the eager audience. Every ME 371 team will be interviewed by the pre-collegiate students who will assign them points. These points will be tallied and the winning team awarded the Sparty Plaque for creating the most thrilling mechanism. This inspiring plaque was designed and fabricated by students at Holt Junior High School more than a decade ago.

**Teams and members**

**Section 1**

<b>Team 1</b> Tim Jang Todd Wolverton	<b>Team 2</b> Alan Seery Michael Uggeri Kyle Watts Susan Whitenight	<b>Team 3</b> Brinn Cochrane Jessica Doody Brooke Peruski Jamie Steinberger	<b>Team 4</b> Megan D’Mello Cody Little Eric Schendel Ethan Weizbacker	<b>Team5</b> David Caples Dan Howarth Matt Morais Miles Turrell
<b>Team 6</b> Caitlyn Cubba Frank Kmet Daniel Schwartz Jeffrey Vonlinsowe	<b>Team 7</b> Jared Horny Jeff Philippart Yubing Su Yongkang Zhou	<b>Team 8</b> Oroje Agari Man Kit Foo Ben Lindemulder Ge Zhu	<b>Team 9</b> Peter Bensel Jon Erickson Lauren Hart Casey Ray	<b>Team 10</b> Robert Boomer William Driscoll Suzanna Normand Shenli Pei

**Section 2**

<b>Team 1</b> Billy Hanley Matt Nees Bryan Mittelstaedt Spencer Turner	<b>Team 2</b> Nassar Alhajri Zach Averill James Miller Nathaniel Sunderlin	<b>Team 3</b> Yeldar Abitayev Christopher Baldwin Grant Golasa Stefan Hebert	<b>Team 4</b> Ante Beslic Joe Casuccio Chad Floria Xiao Zichen	<b>Team 5</b> Benjaman Bennetts Renee Chabon John Jess Jared Lee
<b>Team 6</b> Stephanie Bury Daphne Cai Zhenyu Chen Scott McCarter	<b>Team 7</b> Hassan Alyousef Andrew Kaye Angela Marinich Kevin Pruess	<b>Team 8</b> Katherine Jansen Croix Jastrow Haoqi Liu Hanna VanderMoere	<b>Team 9</b> Hashim Aldabbagh Ann Barrett Eric Darin Zak McLennan	<b>Team 10</b> Rochelle Kirzhner Jeff McCague Maggie Moore Scott Schimp
<b>Team 11</b> Ronald Dewberry Zhijing Liu Travis Schafer Yunfeng Yue				



**ME 412**  
**Heat Transfer Laboratory**

**André Bénard**  
**Associate Professor of Mechanical Engineering**

**Solar Water Heater**

The project team is to design, model, build, and test a system to heat a stream of water using infrared heating lamps. The device will use tap water and the device must have a projected area of no more than 2'x2'. The objective is to maximize the thermal radiant energy gained by the water and to minimize the cost and weight of the solar water heater. The solar water heater must be manufactured by the project team. To test each solar water heater, two infrared heating lamps will be used. The heating lamps will be positioned by the team but cannot be placed closer than 30cm from any part of the system. Temperature of the inlet water and outlet water will be measured, as well as the mass flow rate. Each team will be allowed 15 minutes to demonstrate their solar water heating device. Each team will be asked to present their predictions on the performance of their system before testing.

**Competition Schedule**

<b>Time</b>	<b>Station</b>	<b>Team members</b>		
<b>8:30</b>	A	Jordan Bowman	Shannon Beard	Jonathan Tuse
	B	Andrew Putz	Andrew Stuckwisch	Zachary Albright
<b>8:55</b>	A	Marcus Cannon	Karsten Harns	Zachary Hoyle
	B	Isaac Steinbrunner	Corey Silvis	Kevin Andreassi
<b>9:20</b>	A	Matthew Malek	Daniel Pylar	Raul Maghiar
	B	Sam Balasz	Brian Cheadle	Kihun Kang
<b>9:45</b>	A	Todd Graham	Matthew Gorman	Alex Bergquist
<b>10:10</b>	A	Haley Orr	Russell Tindall	Michael Trotter
	B	Mark Hoyer	Peter Schall	Karl Krug
<b>10:35</b>	A	Isaac Platte	Marcus Johnston	Corey Anderson
	B	Ryan Aenis	Yizheng Wang	Zachary Graham
<b>11:00</b>	A	Michael Skierski	Shawn Wright	Jiantao Liao
	B	David Barrent	William Blancke	Colin Perrault
<b>11:25</b>	A	Sylvia Reiser	Trevor Shane	Joel StCyr
	B	Matthew Bur	Joshua Hill	Paul Snyder
<b>11:50</b>	A	Kellen Fitzpatrick	Evan Koleda	Robert Mishkin
	B	Stephen Campbell	Cameron Gibson	Samantha Hilke



**ME 456**  
**Mechatronics Systems Design**

**Clark Radcliffe**  
**Professor**

## Prototypes of Commercial Products

The students in this course were challenged to develop, test, and demonstrate an innovative design for a commercial product that synthesizes mechanical, electrical, electronic, thermal and/or fluid components with an imbedded microcontroller. Typical applications range from automotive engine controls and robotic manufacturing systems to toys and consumer appliances such as microwave ovens. Each group will make a 20-minute presentation and demonstration of a working prototype of their product.

### Competition Schedule

Team	Time	Members
1	8:00	Kellen Fitzpatrick, April Oesterle, Shivakumar Ramasami, Michael Ryerkerk, Jason Thelen
2	8:25	Stephen Campbell, Samantha Hilke, Andrew Hine, John McCarthy, Kevin Svacha
3	8:50	Matthew Bach, Sam Balasz, Steven Gerdeman, Evan Koleda, Haley Orr
4	9:15	Matthew Bur, Joel Cosner, Todd M Graham, Daniel Holmes, Yueyao Hu
5	9:40	Brian Farber, Corey Silvis, Kyle Sweet, Michael Trotter, Tianyu Zhao
6	10:05	Harrison Cummings, Ping Mi, Jared Staubin, Xiangyu Wang
7	10:30	Alex Bergquist, Elizabeth Kurcz, Cory Snowdin, Brian Weaver, Yan Wu
8	10:55	Matthew Gorman, Stefan Hebert, Yichu Jin, Taylor Mantey
9	11:20	Brian Cheadle, Zachary Graham, Ming Mu, Andrew Stuckwisch, Andrew Wheatley
10	11:45	Jordan Bowman, Sarah Haas, Timothy Polom, Landon Riker, Jonathan Tuse





## ME 471 Mechanical Design II

**Ron Averill**  
Associate Professor



Students in ME 471 were challenged to design, build and test a small scale horizontal motion conveyor system to transport cereal during processing. The design scope includes (1) the drive mechanism, (2) the pan, (3) the supports and (4) all associated hardware. The system should be designed and manufactured so that:

- Energy usage and system cost are minimized. For the most part, these goals are accomplished simultaneously by minimizing the mass of the pan and ensuring smooth motion.
- Product flows rapidly along the length of the pan to maximize throughput.
- Product is distributed uniformly across the width of the pan (to enhance cooling, drying and distribution of the product).
- All metallic structural components are designed to have infinite fatigue life.
- The operation of the system is safe for all personnel and intended products.
- The system is easily maintained, including cleaning, aligning and general maintenance.
- The system is easily assembled and disassembled for use in different configurations and lengths.

The total design performance determines 50% of the final grade, and the other 50% is determined by a final written report that details the concept development and selection process, kinematic analysis, finite element structural analysis, failure analysis, fatigue analysis, cost analysis, integration of marketing elements, and recommendations for future improvement of the design.



**This ME 471 design project was generously sponsored by US Steel.**

Team	Time	Station	Design Team
1	8:00	1	Kathleen Fitzsimons, Daniel Kenny, Andrew Wheatley, Evan Yoder
2	8:14	1	Robert Caldwell, Sean Crump, Yichu Jin, William Lindstrom
1	8:14	2	Kathleen Fitzsimons, Daniel Kenny, Andrew Wheatley, Evan Yoder
3	8:28	1	Peter Dolce, Chenaimoyo Mushiri, Christopher Stanos, Yizheng Wang
1	8:28	2	Kathleen Fitzsimons, Daniel Kenny, Andrew Wheatley, Evan Yoder
2	8:28	3	Robert Caldwell, Sean Crump, Yichu Jin, William Lindstrom
4	8:42	1	Jacob Davenport, Elizabeth Kurcz, Adam Leenheer, Ming Mu
3	8:42	2	Peter Dolce, Chenaimoyo Mushiri, Christopher Stanos, Yizheng Wang
2	8:42	3	Robert Caldwell, Sean Crump, Yichu Jin, William Lindstrom
5	8:56	1	Sarah Kurtz, Jun Li, Ross Otten, Timothy Polom
3	8:56	2	Peter Dolce, Chenaimoyo Mushiri, Christopher Stanos, Yizheng Wang
4	8:56	3	Jacob Davenport, Elizabeth Kurcz, Adam Leenheer, Ming Mu
6	9:10	1	Steven Gorney, Joseph Koterba, Craig Miller, Paul Snyder
5	9:10	2	Sarah Kurtz, Jun Li, Ross Otten, Timothy Polom
4	9:10	3	Jacob Davenport, Elizabeth Kurcz, Adam Leenheer, Ming Mu
7	9:24	1	Daniel Dreliazis, Michael Marshall, Landon Riker, Michael Ryerkerk
5	9:24	2	Sarah Kurtz, Jun Li, Ross Otten, Timothy Polom
6	9:24	3	Steven Gorney, Joseph Koterba, Craig Miller, Paul Snyder
8	9:38	1	Brian Cheadle, April Oesterle, Raymond Peterson, Austin Tokarski
7	9:38	2	Daniel Dreliazis, Michael Marshall, Landon Riker, Michael Ryerkerk
6	9:38	3	Steven Gorney, Joseph Koterba, Craig Miller, Paul Snyder
9	9:52	1	Jennifer Henige, Kihun Kang, Garrett McManaman, Jason Thelen
7	9:52	2	Daniel Dreliazis, Michael Marshall, Landon Riker, Michael Ryerkerk
8	9:52	3	Brian Cheadle, April Oesterle, Raymond Peterson, Austin Tokarski
10	10:06	1	Andrew Hine, Jiao Luo, Stephen Owczarek, Shivakumar Ramasami
9	10:06	2	Jennifer Henige, Kihun Kang, Garrett McManaman, Jason Thelen
8	10:06	3	Brian Cheadle, April Oesterle, Raymond Peterson, Austin Tokarski
11	10:20	1	Evan McCune, Gregory Smiecinski, Yanfeng Wu, Yue Xu
9	10:20	2	Jennifer Henige, Kihun Kang, Garrett McManaman, Jason Thelen
10	10:20	3	Andrew Hine, Jiao Luo, Stephen Owczarek, Shivakumar Ramasami
12	10:34	1	Matthew Bach, Amanda Boyd, Joel Cosner, Eric Rightor
10	10:34	2	Evan McCune, Gregory Smiecinski, Yanfeng Wu, Yue Xu
11	10:34	3	Andrew Hine, Jiao Luo, Stephen Owczarek, Shivakumar Ramasami
13	10:48	1	Benjamin Bosworth, Benjamin Dean, Steven Gerdeman, Brett Hewitt
11	10:48	2	Evan McCune, Gregory Smiecinski, Yanfeng Wu, Yue Xu
12	10:48	3	Matthew Bach, Amanda Boyd, Joel Cosner, Eric Rightor
14	11:02	1	Hasan Alali, John McCarthy, Olukemi Mejabi, Carly Patterson
13	11:02	2	Benjamin Bosworth, Benjamin Dean, Steven Gerdeman, Brett Hewitt
12	11:02	3	Matthew Bach, Amanda Boyd, Joel Cosner, Eric Rightor
15	11:16	1	Rami Janoudi, Jonathan Shapiro, Brandon Smith, Matthew Wiggans
13	11:16	2	Benjamin Bosworth, Benjamin Dean, Steven Gerdeman, Brett Hewitt
14	11:16	3	Hasan Alali, John McCarthy, Olukemi Mejabi, Carly Patterson
15	11:30	2	Rami Janoudi, Jonathan Shapiro, Brandon Smith, Matthew Wiggans
14	11:30	3	Hasan Alali, John McCarthy, Olukemi Mejabi, Carly Patterson
15	11:44	2	Rami Janoudi, Jonathan Shapiro, Brandon Smith, Matthew Wiggans

Station 1: Check in, weigh the device and prepare for assembly  
 Station 2/3(a): Assemble the device and prepare for test  
 Station 2/3(b): One team member delivers the one-minute pitch, followed by the two-minute test. Disassemble immediately following the post-test celebration.



**Success stories don't just happen. They are made.**



**BOSCH**  
Invented for life

**Take your first step on a management career path.** Our Professional Development Programs put you on the fast track for professional and leadership opportunities throughout Bosch. Within 24 months you will complete four rotations, one of which is international. You will be partnered with an executive mentor for professional coaching and gain leadership exposure through structured networking events. You'll get to know the company inside and out, make independent contributions and cultivate your skill set. Start your career with Bosch's Professional Development Training Program for Bachelor's level candidates or the Junior Managers Program for Master's graduates.

What should you bring to the table? An innovative mindset, flexibility, results-oriented spirit and, of course, leadership potential. Think you've got it? Join Bosch and begin your exciting career today.

**Apply now.** Discover your potential with our Professional Development Programs.

[www.boschcampus.com](http://www.boschcampus.com)

# The Capstone Projects



**Dr. Ronald Averill**  
Associate Professor of  
Mechanical Engineering



**Dr. Giles Brereton**  
Associate Professor of  
Mechanical Engineering

## Presentation Schedule – Lake Superior Room

Time	Team Sponsor	Project Title
8:30 a.m.	Ford	Diesel Fuel Injection Systems Air Separator
8:47 a.m.	Chrysler	Retractable Seat Insert for Comfort
9:04 a.m.	Robert Bosch	Test Rig for Analysis of Diesel Injector Sprays
9:21 a.m.	U.S. Steel	Automated Measurement of Pipe Inner Diameters
9:38 a.m.	Williams International	Design of a Quieter Test-Cell Air Intake
9:55 a.m.	ZF Lemforder	A Tool for Ball-Joint Torque Measurement
10:12 a.m.	Break	
10:30 a.m.	Whirlpool	Ice and Water Dispensation from Refrigerators
10:47 a.m.	Whirlpool	Door that Eliminates Line Disconnections
11:04 a.m.	Haworth	Design of a Moveable Wall System
11:21 a.m.	GM Foundation	Pedestrian Sound Simulator for Electric Vehicle
11:38 a.m.	U.S. Air Force Research Laboratory	Active Cooling Control of Electrical Racks

# ME 481 Mechanical Engineering Design Projects

ME481 is required for all mechanical engineering majors at MSU. The course provides students with a team-based capstone design experience:

- Using the technical expertise, communication skills, and teaming methodologies they have learned throughout their mechanical engineering curriculum, along with their creativity, to solve real world problems.
- Collaborating with practicing engineers to address problems sponsored by industry.
- Developing new products or re-designing existing products to reduce costs or enhance reliability.
- Interacting with large, medium and small companies in the automotive, defense, aerospace, consumer products, interior design and material processing industries.

Project sponsors include Bosch LLC, Chrysler, LLC; Ford Motor Company; General Motors Foundation; Haworth; U.S. Air Force Research Laboratory; U.S. Steel; Whirlpool Corporation; Williams International; and ZF Lemforder

# Ford Motor Company Diesel Fuel Injection Systems Air Separator

Ford Motor Company is one of the world's leading automobile manufacturers. A significant number of its vehicles are powered by Diesel engines, which are growing in popularity because of the higher efficiencies at which they operate. When Diesel fuel is added to fuel tanks, it usually contains a significant number of dissolved air bubbles. This fuel is then pumped to the common rail that feeds the fuel injectors at high pressures, as high-pressure fuel injection allows precise control of combustion in the engine. However, dissolved air impedes the delivery of Diesel fuel to the injectors at high pressures, making it imperative that it be removed.

The MSU team is exploring how different kinds of compact filtration devices can be used to remove air from Diesel fuel. A prototype testing rig has been developed and will be used to assess the effectiveness of different designs of filtration systems, from which an optimal system will be chosen.

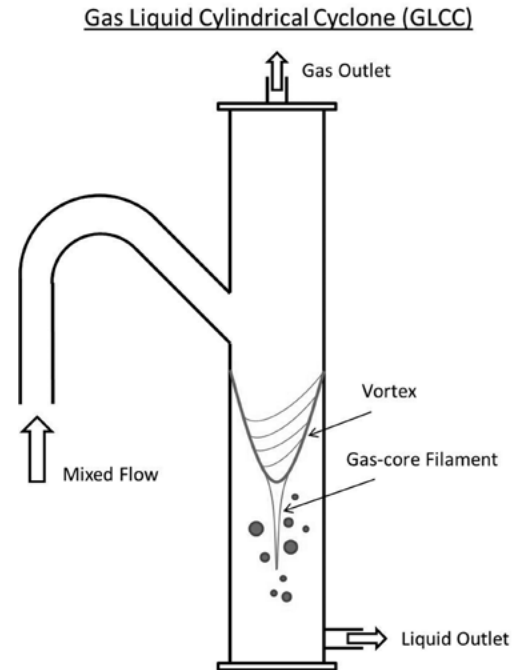

## Michigan State University

### Team Members

**Alex Bergquist**  
Grand Rapids, Michigan

**Matthew Gorman**  
Livonia, Michigan

**Patrick O'Malley**  
Rochester Hills, Michigan

**Trevor Shane**  
Bellaire, Michigan

## Ford

### Project Sponsor

**Carlos Armesto**  
Dearborn, Michigan

# Chrysler Group LLC

## Retractable Seat Insert for Comfort

The Seat Engineering group at Chrysler LLC is interested in the development of a concept for a retractable seat insert which permits enhanced seat adjustability. Some individuals prefer firm seats, while others prefer a softer feel. The ability of customers to make their own choice of seat firmness provides a competitive advantage in the automotive industry, allowing people of different physical stature and expectations to adjust their seating for optimal comfort.

The MSU design team studied several current research concepts in seat design to determine the features of a seat that are of the most importance to the majority of passengers. The three most important parameters were found to be: fit; feel; and support; and are considered at each stage in the process of designing a seat insert to optimize the passenger's experience. By using CAD software and 3D models, the team was able to gain a better understanding of the seat's mechanics and thereby improve the functionality of the design. The expected outcome is a prototype seat which offers a broad range of adjustability and is applicable to the entire range of seating, from sport to luxury.

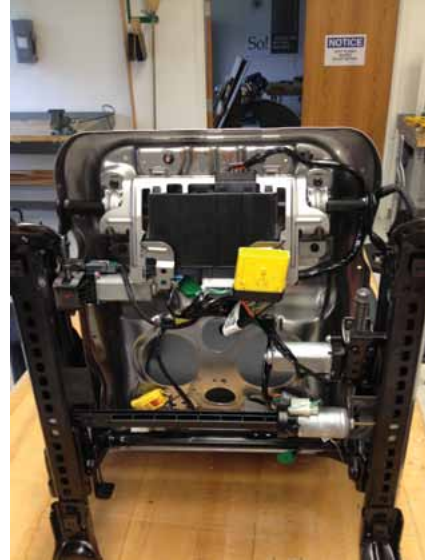

### Michigan State University Team Members

**William Blancke**  
Washington, Michigan

**Werner Dahm**  
Ann Arbor, Michigan

**Cameron Gibson**  
Rochester, Michigan

**Colin Perrault**  
Burr Oak, Michigan

### Chrysler Project Sponsors

**Travis Bechtel**  
Auburn Hills, Michigan

**Michael Butler**  
Auburn Hills, Michigan

# Robert Bosch, LLC

## Test Rig for Analysis of Diesel Injector Sprays

Bosch is one of the world's leading manufacturers of automotive components, which include solenoid and piezo-electric fuel injectors. When fuel is injected into engine cylinders as a spray, the shape of the spray and the distribution of droplets within it can have a significant effect on the subsequent combustion, and thus on the performance of the engine. It is therefore important to ensure that sprays produced by fuel injectors take the desired shape and distribute fuel droplets of the desired size, prior to installation in engines. Since poor fuel-spray patterns can result from imperfections in the design and manufacturing of injectors, it is useful to have a test rig with which fuel-spray patterns can be observed and analyzed. Such rigs are also useful for developing injectors with improved and optimized fuel-spray patterns.

Bosch currently has advanced test rigs in Europe for spray pattern visualization, which are expensive, complicated to operate, and are not practical to use at their Farmington Hills facility. Instead, Bosch would like a simpler, low-cost rig for visualizing fuel-spray patterns that can be mounted on an existing hydraulic test bench, which supplies high pressure fuel to the injector and provides the electrical signal for activating the injector. The purpose of this project is to design a prototype low-cost rig that can be used to quickly check the quality of the spray produced by any Bosch injector.

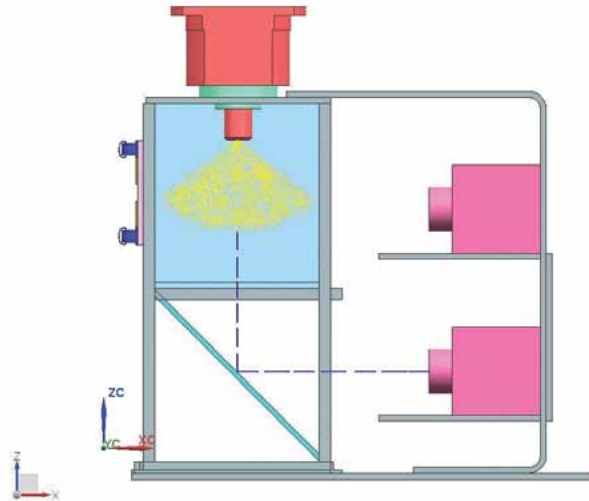

**BOSCH**  
Invented for life

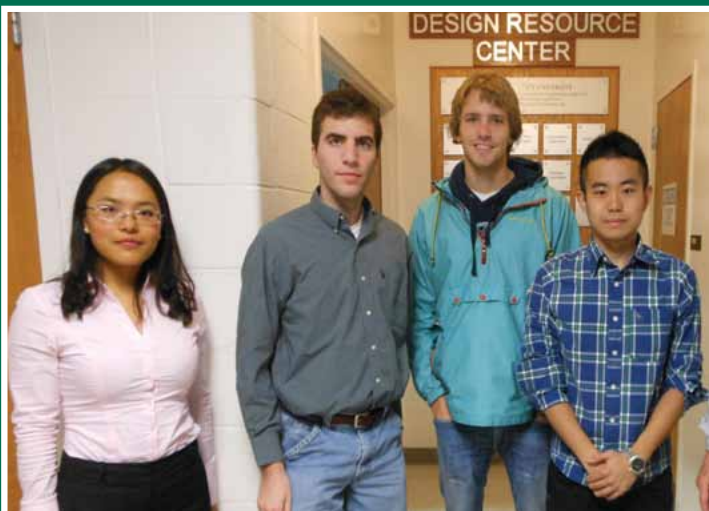

### Michigan State University

#### Team Members

**Jordan Bowman**  
Jackson, Michigan

**Zachary Graham**  
Grosse Pointe, Michigan

**Jiantao Liao**  
Tianhe Dist Guangzhou, China

**Yirang Liu**  
Haidian District Beijing, China

### Robert Bosch, LLC

#### Project Sponsor

**Matt Thorington**  
Farmington Hills, Michigan

# United States Steel – Great Lakes Works

## Automated Measurement of Pipe Inner Diameters

United States Steel Corporation is the largest integrated steel producer in the U.S. with an annual raw steelmaking capability of 29.3 million net tons. The company produces steel tubular and sheet products for the appliance, automotive, construction, container, gas, and oil industries. US Steel requires a device to measure the inner dimensions of pipes to ensure that their diameter, ovality, and straightness meet quality control standards.

The steel tubes range from 2.375" to 3.5" in outside diameter and from 28 to 34 feet in length. The MSU team is looking into smart techniques for gauging pipe inner diameters that avoid the manual use of mandrels, such as designing a simple robot to conduct this task. A successful design will ensure that pipe quality standards are measured with increased safety and reduced equipment costs, maintenance costs and manpower requirements.

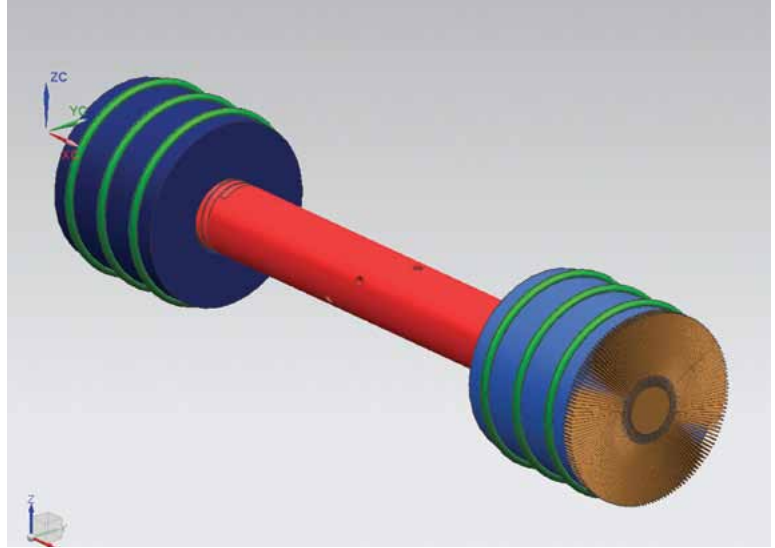

### Michigan State University Team Members

**Ryan Aenis**  
Central Lake, Michigan

**Zachary Albright**  
Grand Haven, Michigan

**Sarah Haas**  
Fenton, Michigan

**Andrew Stuckwisch**  
Grand Blanc, Michigan

### United States Steel Project Sponsor

**Marty Beaver**  
Great Lakes Works,  
Ecorse, Michigan

# Williams International, LLC

## Design of a Quieter Test-Cell Air Intake

Williams International is an aerospace and defense company, specializing in the design and manufacturing of small gas turbine engines. These engines are tested in test cells, the noise from which Williams is interested in minimizing. Williams' facility engineers have identified the air intakes positioned on top of a recently constructed test cell as a likely source of noise. The intakes are truss-supported, mushroom-shaped hoods, composed of aluminum sheet metal that provide protection from the weather but offer little sound absorption.

The goals of the MSU design team are two-fold: to identify the principal source of test-cell noise and to design a solution. Therefore the team expects to incorporate principles of sound dampening in structures and principles of energy absorption in fluid flow in a design solution. The expected outcome will be a prototype and detailed design of an intake which optimizes the facility's efficiency and minimizes its noise leakage.

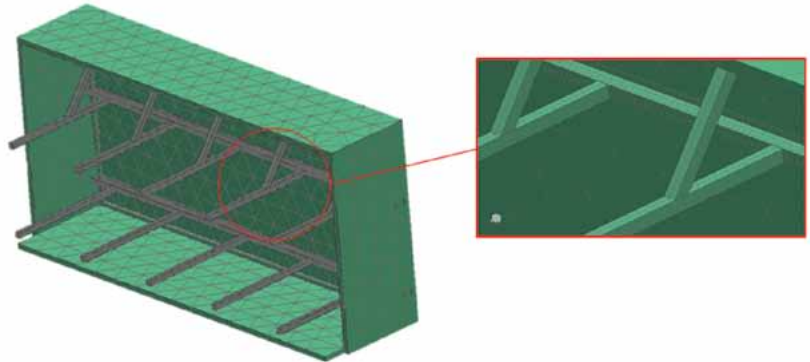

### Michigan State University Team Members

**Marcus Cannon**  
Farmington Hills, Michigan

**Karsten Harns**  
Lansing, Michigan

**Zachary Hoyle**  
Midland, Michigan

**Joel Stcyr**  
Rochester Hills, Michigan

### Williams International Project Sponsor

**Thomas Hartley**  
Commerce Township, Michigan



# ZF Lemforder Corporation

## A Tool for Ball-Joint Torque Measurement

The ZF Group is one of the world's largest automotive suppliers, developing and producing transmissions, steering systems, axles, and chassis components. ZF Lemforder is a subsidiary of this group that specializes in steering and suspension technology and, in particular, ball-joint and suspension-linkage testing. Ball joints are utilized in several parts of a vehicle's chassis, where multi-axis rotation is needed, and undergo extensive testing for their friction, torque, elasticity, wear, and fatigue characteristics. ZF is interested in improving the accuracy with which the torque required to rotate ball joints during testing is measured, since this torque measurement correlates well with ball-joint service life.

The MSU team is designing a standardized tool for measuring ball-joint torque that can be used to make consistent measurements at multiple ZF facilities. The tool has to be compatible with existing test machinery and must provide a torque reading that is not affected by changes in temperature, elevation, electrical current and time. This tool will help eliminate inconsistencies in torque measurements on ball joints manufactured at different plants and so improve the company's manufacturing process.



### Michigan State University Team Members

**Shannon Beard**  
Saginaw, Michigan

**Kellen Fitzpatrick**  
Grand Rapids, Michigan

**Samantha Hilk**  
Saginaw, Michigan

**Jonathan Tuse**  
Niles, Michigan

### ZF Lemforder Project Sponsor

**Andrew Chen**  
Northville, Michigan

# Whirlpool Corporation

## Ice and Water Dispensation from Refrigerators

Whirlpool Corporation is one of the largest appliance-manufacturing companies in the United States and sells its products throughout the world. A number of its refrigerator models dispense both ice and water to the consumer, and Whirlpool is interested in optimizing the design of these dispensers to permit large containers to be filled from shallow dispensing wells. In designing such dispensing systems, it is most important that they be both energy-efficient and compact, so that as much interior space as possible is available for food storage.

The MSU team will evaluate a set of dispenser designs that are customized for one of Whirlpool's best-selling refrigerators, supported by theoretical calculations and experimental tests. A functioning prototype of the most promising design will then be built and tested for functionality and reliability. This prototype will then be delivered to Whirlpool for further evaluation.

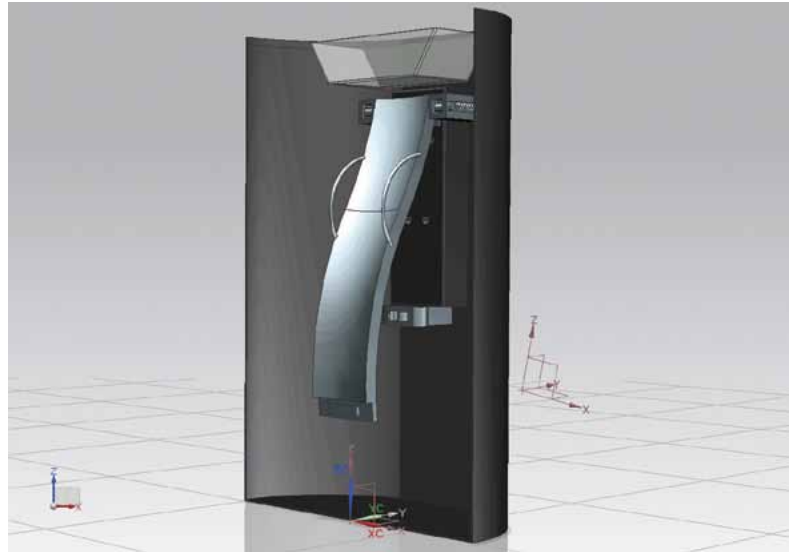

### Michigan State University Team Members

**Michael Aurino**  
Swartz Creek, Michigan

**Mark Davison**  
Bloomfield Hills, Michigan

**Matthew Hoffdal**  
Swartz Creek, Michigan

**Matthew Witmer**  
St. Clair Shores, Michigan

### Whirlpool Project Sponsor

**Greg Hortin**  
Evansville, Indiana

# Whirlpool Corporation

## Door that Eliminates Line Disconnections

Whirlpool Corporation is one of the largest appliance-manufacturing companies in the United States and sells its products throughout the world. In a number of its refrigerator models, electrical and water lines run from the main cabinet to the door through a hinge, to provide power and water to an icemaker and a water dispenser. If the door is removed during installation or servicing, these lines must be disconnected and then reconnected, which can potentially result in water leakage or intermittent electrical contact. Whirlpool is interested in design concepts that preserve the functionality of icemakers and water dispensers in refrigerator front doors and allows them to be maintained easily, while avoiding the problems of line disconnection and reconnection.

The MSU team will evaluate a set of conceptual line-routing designs that satisfy Whirlpool's constraints. An optimal design will be selected and then customized for a particular Whirlpool refrigerator. A prototype of the most promising design will then be built and tested for functionality and reliability, and delivered to Whirlpool for further evaluation.



### Michigan State University

#### Team Members

**Sam Balasz**  
Charlevoix, Michigan

**Matthew Bur**  
Farmington Hills, Michigan

**Kevin Svacha**  
Fort Gratiot, Michigan

**Benjamin Zondlak**  
Midland, Michigan

### Whirlpool

#### Project Sponsor

**Greg Hortin**  
Evansville, Indiana

# Haworth Inc.

## Design of a Moveable Wall System

Haworth is an architectural interior and office design company located in Holland, MI that produces a wide range of office furniture products such as moveable walls, raised floors, furniture systems, seating, and wood-case goods, while striving for and promoting environmental sustainability. Haworth's moveable wall installations, made from materials such as glass and drywall, are designed to allow entire floor-to-ceiling walls to be taken down and reassembled in different configurations in a short amount of time to allow offices to be adapted to meet the changing needs of a company. To increase its market share, Haworth is considering introducing a new kind of moveable wall with a surface to which papers can be pinned, tacked or stapled directly.

The goal of this project is to design a prototype pin-tackable moveable wall for office installation which meets Haworth's expectations for durability, ease of installation and assembly, and provides a high level of aesthetic quality, that can be put into production with minimal cost and manufactured in the shortest time possible.

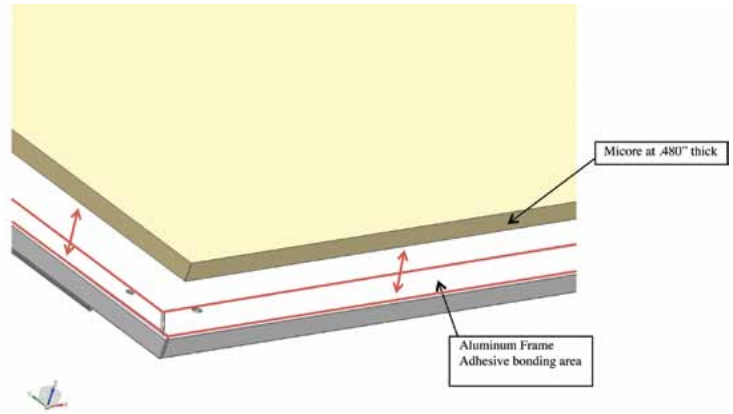
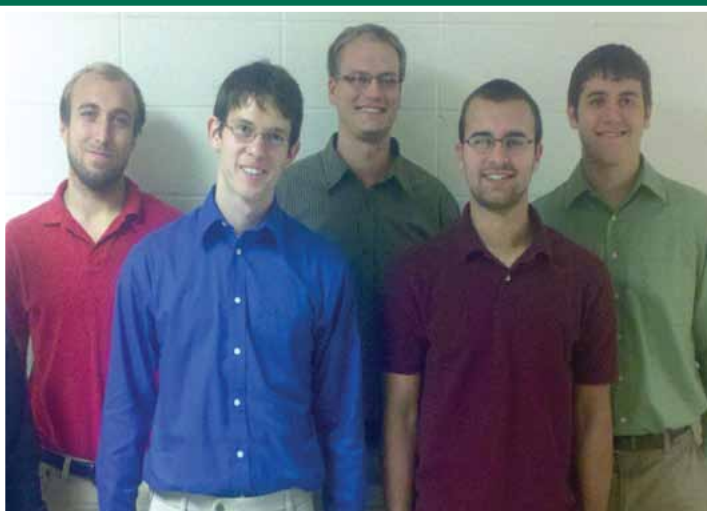

Figure 1. Faces of adhesive bonding (exploded view)

# HAWORTH®



### Michigan State University

#### Team Members

**Mark Hoyer**  
Rochester, Michigan

**Evan Koleda**  
Utica, Michigan

**Karl Krug**  
Grand Haven, Michigan

**Robert Mishkin**  
East Lansing, Michigan

**Peter Schall**  
Williamston, Michigan

### Haworth

#### Project Sponsor

**Scott Compton**  
Holland, Michigan

# General Motors Foundation Pedestrian Sound Simulator for Electric Vehicle

General Motors is one of the world's leading automobile manufacturers and has been developing new hybrid electric vehicles (HEVs) for production. While HEVs have significant environmental advantages over vehicles with conventional engines, their ultra-quiet performance is of concern to particular groups such as the sight impaired and pedestrians, who are often unaware of their presence.

The MSU design team is developing a computer-based program that will permit General Motors designers and engineers to design the sound of electric hybrid vehicles of the future. Its goal is to create a computer program with a graphical user interface that will enable the user to modify and fine-tune the sound signatures (e.g. frequency and pitch) that are emitted for different inputs. For example, if the throttle position is the input, the output is a sound like the acceleration of a vehicle, emitted by speakers. The sounds generated by the software should be adjustable to reproduce different vehicle sounds for different products, targeted at different customers. An additional proposed feature of this program will be a modular cockpit simulator, which will allow audio designers and engineers to test the acoustic signatures they have created and refine them as needed.

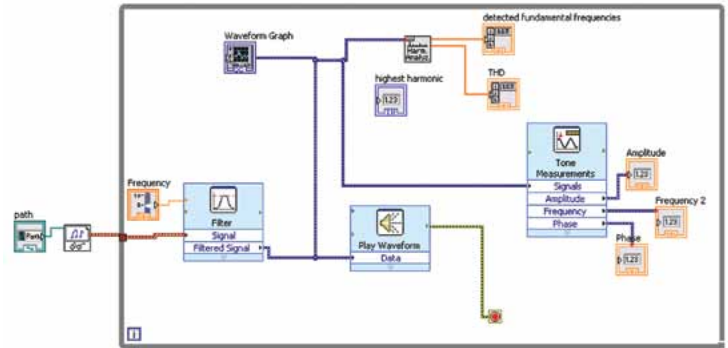

**Michigan State University**  
Team Members

**Stephen Campbell**  
Battle Creek, Michigan

**Haley Orr**  
Royal Oak, Michigan

**Russell Tindall**  
Romeo, Michigan

**Michael Trotter**  
Linden, Michigan

**GM Foundation**  
Project Sponsor

**Andrew Herman**  
Warren, Michigan

# U.S. Air Force Research Laboratory

## Active Cooling Control of Electrical Racks

The US Air Force routinely deploys sophisticated electronic systems to remote parts of the world to support military, civilian, and humanitarian missions. Many such systems are rack-mounted electronics that may be deployed to hot, humid locations and require significant cooling heat transfer to maintain their functionality. To address this cooling need, the Air Force Research Laboratory has proposed a challenge problem: to develop an innovative 'all-purpose' 3ft<sup>3</sup> equipment enclosure that can continually dissipate 2 kilowatts of power. The cooled space must be maintained between 15 and 45 °C and cannot be contaminated with outside debris or toxic chemicals (such as typical refrigerants).

The MSU design team is proposing a cooling solution comprising a conventional external refrigeration system that is connected to the enclosure by a water circuit. Thermodynamic and heat transfer analyses are used to optimize the design of a prototype system, the performance of which will be tested experimentally.



### Michigan State University

#### Team Members

**Jarrold Heck**  
Battle Creek, Michigan

**Matthew Malek**  
Rochester Hills, Michigan

**Michael Mehall**  
Kalamazoo, Michigan

**Khoa Nguyen**  
Grandville, Michigan

**Daniel Pylar**  
Portage, Michigan

### USAF Research Laboratory

#### Project Sponsor

**Ben Bosma**  
Wright Patterson AFB, Ohio

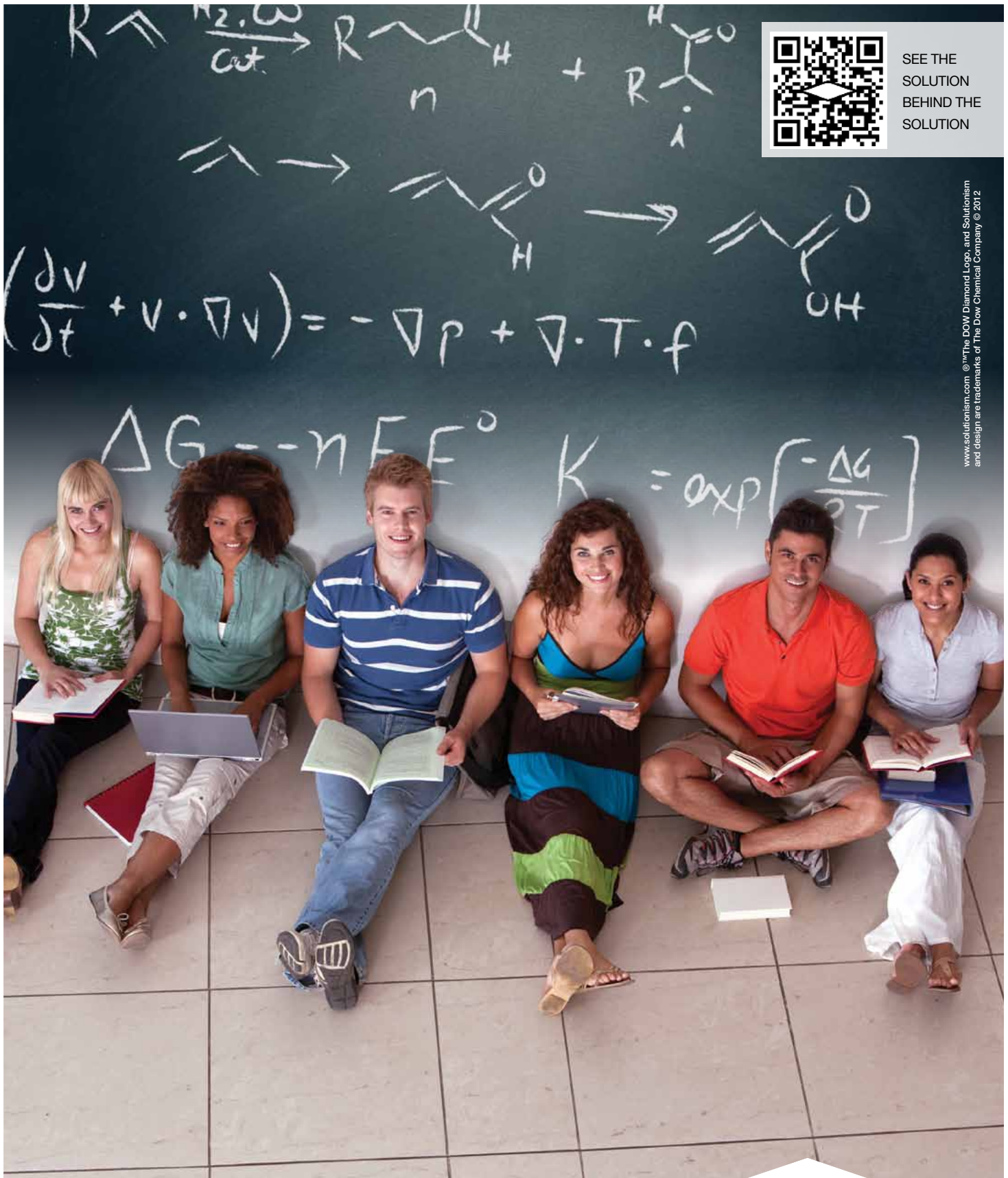

SEE THE  
SOLUTION  
BEHIND THE  
SOLUTION

www.solutionism.com © The Dow Diamond Logo, and Solutionism and design are trademarks of The Dow Chemical Company © 2012

## BE A PART OF THE SOLUTION.

We're for what goes after the equals sign. We are chemists. We are scientists. We are thinkers. Dreamers. Believers. And doers. We are Solutionists. At Dow, we believe that together, the elements of science and the human element can solve anything. Learn more about career opportunities at Dow at [www.careersatdow.com](http://www.careersatdow.com). **Solutionism. The new optimism.™**



OFFICIAL CHEMISTRY COMPANY

# Design Day Awards

## ME 481 Thomas Alva Edison Undergraduate Design Award

The Edison Scholars are recognized as the ME 481 Design Team that has produced the most outstanding project. A jury of experts from industry and academia evaluate the final reports, the posters, and the final oral presentations in determining the award winners. Teams operating under ME 481 that include members from other departments and colleges are also eligible for this award.



Professor Clark Radcliffe, Kyle Justus, Gregory Thomas, Gerald Gentz, Michael O'Brien. Not shown: J.T. Whitman

## ME 481 Oral Presentation Award

The best ME 481 oral presentation as determined by the ME 481 students is recognized with this award.



Professor Clark Radcliffe, Kyle Schubel, Brian White  
Not shown: Eric Beatham, Anthony Han, Jeff Narkis

## ME 481 Outstanding Poster Award

The ME 481 Outstanding Poster Award recognizes the best poster presented by an ME 481 design project team as judged by a team of individuals from industry and academia. Judging is based on both technical content and aesthetic layout.



Professor Clark Radcliffe, Nicholas Schooley, Andrew Nuttall, Austin Deneff, Josh Dewalt, Jared St. Aubin



---

## ME 471 Machine Design Award

The student team members winning the ME 471 competition at Design Day are recognized with the Machine Design Award. The award winners are determined by the course instructors based on team scoring in the competition. The funding for this award is provided by the Shell Oil Company.



Professor Alfred Loos, William Blancke, Andrew Putz,  
Zachary Timpf,

---

## ME 371 Mechanical Design I Kids' Choice Award

The precollege students participating in Design Day vote for the most outstanding ME 371 project. The winning team is designated as the Kids' Choice Award. This team is recognized with a plaque designed and manufactured by Mr. Jon Thon's 7th grade technology class at Holt Junior High School.



Professor Farhang Pourboghra, Matthew Bach, Mariah  
Krebs, Shivakumar Ramasami, Jason ThelenSmith

---

## ME 412 Heat Transfer Design Award

The student team members winning the ME 412 competition at Design Day are recognized by the Heat Transfer Design Award. The award winners are determined by the course instructor based on team scoring in the competition.



Michael Mehall, Academic Specialist Laura Genik, Nicholas Schooley

# MOST OF US GO PRO IN SOMETHING OTHER THAN SPORTS



*Michael Sadler  
Football  
Applied Engineering Sciences*

*Chenai Mushiri  
Golf  
Mechanical Engineering*

*David Zoltowski  
Swimming & Diving  
Electrical Engineering*

*Stephanie Seibert  
Swimming  
Applied Engineering Sciences*

There are over 400,000  
NCAA student-athletes,  
and most of us will  
go pro in something other  
than sports.

*Garth Yenter  
Wrestling  
Chemical Engineering*





The only thing more  
diverse than our products....  
are the people who create them.



Whirlpool Corporation, named by *FORTUNE* magazine as a **Top 10 Global Company for Leaders**, offers 9 Leadership Development Programs for business and engineering graduates.

For more information about our full-time and  
internship programs, visit:

[www.WhirlpoolCareers.com](http://www.WhirlpoolCareers.com)





*Directing Partner Sponsor of Design Day*

**For information on  
sponsoring Design Day  
and design projects, contact**

Dr. Wayne Dyksen  
Executive Director, Design Day  
(517) 353-5573 [dyksen@msu.edu](mailto:dyksen@msu.edu)

Jennifer Jennings  
Director, Design Day  
(517) 432-6573 [jenning@msu.edu](mailto:jenning@msu.edu)