

ECE 202 (Fall 2007)
 Homework No. 11
 Due: Wednesday, 12/5/2007

Instructions: Draw a box around to indicate each answer. Failure to do so will cost you 2 pts per offence.

Total =120 pts

(P.1) [10 pts] Solve Problem 15-4 in text.

(P.2) [10 pts] Solve Problem 15-12 in text. Calculate the input resistance as seen into the primary input terminals of the transformer. Express your results in the time domain.

(P.3) [26 pts] The coils in Figure 1 have $L_1 = 40$ mH, $L_2 = 5$ mH, and a coupling coefficient $k = 0.6$. The signals are $v_1(t) = 10 \cos(\omega t)$ V, $i_2(t) = 2 \sin(\omega t)$ A, and $\omega = 2000$ rad/s.

(a)[14] Using the given values, draw and clearly label the **phasor domain** equivalent circuit (similar to that given in the bottom of p.15 in Ch. 15 of the course notes, but with $s = j\omega$).

(b)[12] Find $i_1(t)$ and $v_2(t)$.

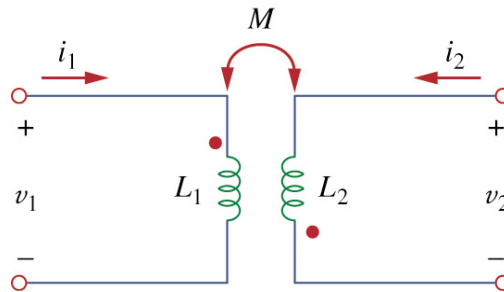

Figure 1 Circuit for Problem 2

(P.4) [13 pts] Find \mathbf{I}_1 and \mathbf{I}_2 in the circuit of Figure 2 and express your answers in polar form. Calculate the power absorbed by the 4- Ω resistor.

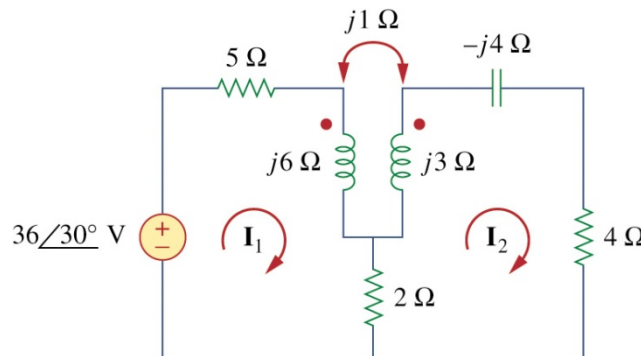

Figure 2 Circuit for Problem 3

(P.5) [16 pts] A 110-V rms, 60-Hz source is applied to a load impedance, \mathbf{Z} . The apparent power entering the load is 120 VA at a power factor of 0.707 lagging.

- (a) Calculate the complex power.
- (b) Find the rms current supplied to the load.
- (c) Determine \mathbf{Z} .
- (d) Assuming that \mathbf{Z} has the form $\mathbf{Z} = R + j\omega L$, find values of R and L .

(P.6) [18 pts] For the following voltage and current phasors, calculate the complex power, apparent power, real power, reactive power, and the power factor. Specify (and explain briefly why) whether the pf is leading or lagging.

- (a) $\mathbf{V} = 220 \angle 30^\circ$ V rms, $\mathbf{I} = 0.5 \angle 60^\circ$ A rms
- (b) $\mathbf{V} = 250 \angle -10^\circ$ V rms, $\mathbf{I} = 6.2 \angle -25^\circ$ A rms

(P.7) [15 pts] Solve Problem 16-27 in text.

(P.8) [12 pts] Solve Problem 16-36 in text. (For part (b), express the total complex power in rectangular form.)