

# Current-input current-output CMOS logarithmic amplifier based on translinear Ohm's law

C. Huang and S. Chakrabartty

State-of-the-art logarithmic amplifiers use a transimpedance technique based on the exponential dependence between input current and output voltage as exhibited by p-n junction diodes, bipolar transistors and MOS transistors in the subthreshold region. Presented is a CMOS current-input current-output logarithmic amplifier based on a translinear Ohm's law principle which involves a floating voltage source and a passive resistor embedded within a translinear loop. It is demonstrated that the input–output range of the proposed logarithmic amplifier can be controlled using a reference bias and the response of the amplifier can be temperature compensated using a PTAT and a resistive cancellation technique.

**Introduction:** Functionally, the output of a logarithmic amplifier is related to its input according to a log function which is used to compress the dynamic range of the input signals [1]. The most popular technique for implementing logarithmic amplifiers is the transimpedance based approach which exploits the exponential dependence between the current and the voltage across a p-n junction diode, a bipolar transistor or a MOSFET in the subthreshold region [2]. Because the output of a transimpedance amplifier is a voltage signal, its dynamic range is limited by the supply voltage. Also, a transimpedance amplifier inherently exhibits high sensitivity to temperature variations and therefore requires additional compensation circuitry.

In this Letter, we propose a current-input current-output logarithmic amplifier based on a novel translinear Ohm's law technique. It is an extension of the celebrated translinear principle exploiting the exponential current-to-voltage characteristic of bipolar and CMOS transistors [3]. The translinear Ohm's law is first explained using the conceptual circuit shown in Fig. 1 which consists of several diodes  $D_{1-4}$  acting as translinear elements, a floating voltage source  $\Delta V$  and a resistor  $R$ . Assuming the voltage drop across each diode is denoted by  $V_1$  to  $V_4$  and the current flowing through  $R$  is denoted by  $I_R$ , the direct application of Kirchhoff's voltage law gives

$$V_1 + V_2 + \Delta V = V_3 + V_4 + I_R \times R \quad (1)$$

which after scaling and applying the translinear diode equation  $I_{1-4} = I_S \exp(V_{1-4}/U_T)$ , leads to

$$I_1 I_2 \exp\left(\frac{\Delta V}{U_T}\right) = I_3 I_4 \exp\left(\frac{I_R R}{U_T}\right) \quad (2)$$

or equivalently

$$I_R = \frac{\Delta V}{R} + \frac{U_T}{R} \ln\left(\frac{I_1 I_2}{I_3 I_4}\right) \quad (3)$$

$U_T$  in (2) and (3) refers to the thermal voltage which is linear to absolute temperature and approximately equals to 26 mV at room temperature. Equation (3) can be further simplified to

$$I_R = \frac{\Delta V}{R} \quad (4)$$

which is equivalent to Ohm's law only when the translinear condition  $I_1 I_2 = I_3 I_4$  is satisfied, hence the name 'translinear Ohm's law'. Note that the circuit in Fig. 1 only demonstrates the conceptual principle, so the loop can be implemented using different network connections and with different numbers of elements.

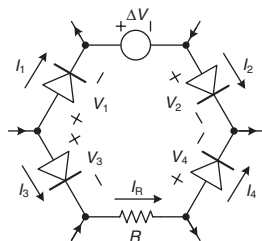

Fig. 1 Conceptual illustration of translinear Ohm's law

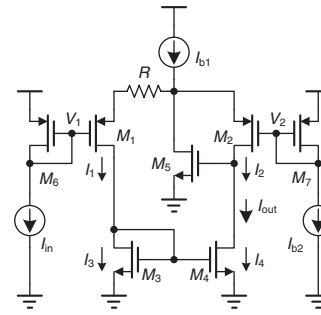

Fig. 2 Schematic of translinear logarithmic current converter

**Operation principle:** The basic circuit for the proposed logarithmic amplifier is shown in Fig. 2 and is derived from a translinear circuit which was reported in [4]. All the transistors  $M_1$  to  $M_4$  are biased in the subthreshold region and the drain-to-source voltage is larger than 100 mV, in which case the transistors satisfy the following translinear relation [5]

$$\text{nMOS: } I_{DS} = S I_{D0} \exp\left(\frac{V_G}{n U_T}\right) \exp\left(\frac{-V_S}{U_T}\right) \quad (5)$$

$$\text{pMOS: } I_{DS} = S I_{D0} \exp\left(\frac{-V_G}{n U_T}\right) \exp\left(\frac{V_S}{U_T}\right) \quad (6)$$

where  $S$ ,  $I_{D0}$ ,  $n$ ,  $U_T$ ,  $V_G$  and  $V_S$  are the aspect ratio, characteristic current, subthreshold slope, thermal voltage, gate and source voltage referred to bulk potential ( $V_{dd}$  or gnd), respectively. Transistor  $M_5$  serves as a feedback element which reduces the output impedance at the drain of  $M_2$ . If the sizes of the transistors are considered to be equal, the current mirror formed by  $M_3$  and  $M_4$  ensures  $I_1 I_2 = I_3 I_4$ . Then, using the translinear Ohm's law the output current  $I_{out}$  can be expressed as

$$I_{out} = \frac{V(I_{in})}{R} \quad (7)$$

where the floating-voltage source  $V(I_{in})$  equals the difference in gate voltages of transistors  $M_1$  and  $M_2$ , which are mirrored from  $M_6$  and  $M_7$  and can be expressed as

$$V(I_{in}) = n U_T \ln\left(\frac{I_{in}}{I_{b2}}\right) \quad (8)$$

Thus, the output current is proportional to the logarithm of the input current and should satisfy  $I_{in} > I_{b2}$  for the circuit to be operational.

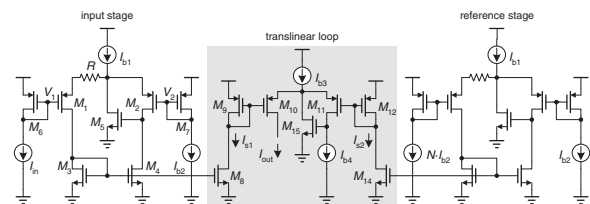

Fig. 3 Completed logarithmic current converter for temperature independency

**Implementation:** Equation (8) reveals that the response of the logarithmic amplifier varies with temperature owing to several factors which include: (a) the thermal voltage  $U_T$ ; (b) the resistor  $R$ ; and (c) the subthreshold slope  $n$ . Fig. 3 shows the complete implementation of a temperature compensated logarithmic amplifier based on the proposed translinear Ohm's law principle. In Fig. 3,  $M_1$  to  $M_7$  act as the input stage which generates  $I_{S1}$  from the input current according to (8). Another same circuit acts as the reference stage which generates  $I_{S2}$  as

$$I_{S2} = \frac{n U_T}{R} \ln(N) \quad (9)$$

where  $N$  is the ratio between the biasing current. The translinear loop formed by  $M_9$  to  $M_{12}$  cancels the temperature dependent scaling factor in (8) and (9) using the translinear principle satisfying

$$I_{S1} I_{b4} = I_{out} I_{S2} \quad (10)$$

Note that  $I_{b3}$  in Fig. 3 is an external biasing current to establish the translinear loop which is usually 10 times larger than  $I_{b4}$ .  $M_{15}$  is added at the input of  $I_{b4}$  to ensure  $M_{11}$  to be in the saturation region. Inserting (8) and (9) into (10), the output current can be expressed as

$$I_{out} = \frac{I_{b4}}{\ln(N)} \ln\left(\frac{I_{in}}{I_{b2}}\right) \quad (11)$$

From (11) it can be seen that theoretically all the temperature dependent terms have been cancelled out and the input–output relationship only depends on the ratio of currents. The output scale of the current conversion can be adjusted by current  $I_{b4}$ .

**Results:** The proposed current conversion circuit is simulated using parameters obtained from a 0.5  $\mu\text{m}$  standard CMOS process. The DC response of the circuit is shown in Fig. 4 which is compared with an ideal logarithmic amplifier response. The input current was varied from 10 pA to 100 nA and for each simulation with different value of  $I_{b4}$ . The results show close agreement between the simulated result and the mathematical model given by (11). The results also demonstrate that a larger dynamic range can be achieved by increasing  $I_{b4}$ .

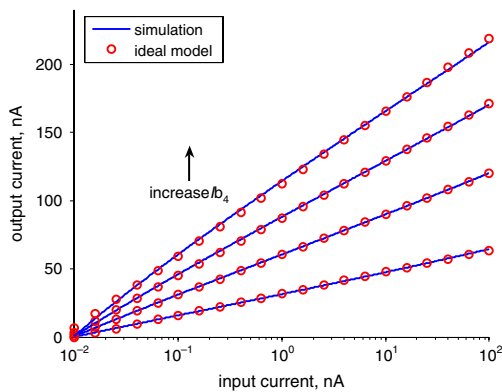

Fig. 4 Simulation results for logarithmic current conversion

For the next set of experiments, the temperature was varied from  $-30$  to  $40^\circ\text{C}$  and the currents  $I_{S1}$ ,  $I_{S2}$  and  $I_{out}$  were compared. Each current was normalised to its current level at  $-30^\circ\text{C}$ . Since all the currents are in the subthreshold level,  $I_{S1}$  and  $I_{S2}$  are changing dramatically with temperature according to (8) and (9). However, the temperature dependencies of  $I_{S1}$  and  $I_{S2}$  are found to be cancelled at the output current  $I_{out}$  using the translinear loop as shown in Fig. 5.

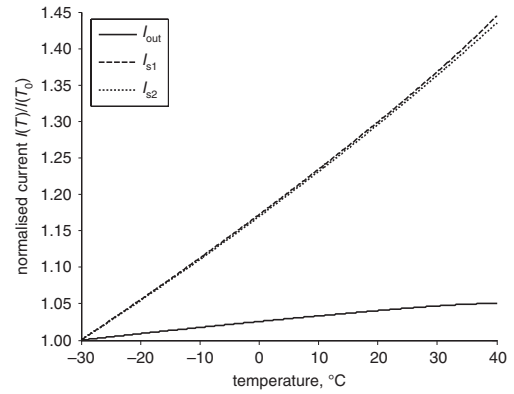

Fig. 5 Simulation results for temperature dependency

**Conclusion:** A current-input, current-output logarithmic amplifier circuit is proposed based on the translinear Ohm's law. The circuit implements a current dependent floating voltage source embedded in a translinear loop consisting of a resistive element. Temperature dependence and circuit nonlinearity are compensated using additional translinear loops and a PTAT current reference.

**Acknowledgment:** This research was supported in part by the National Science Foundation (NSF), CMMI (grant 0700632, CAREER-0954752).

© The Institution of Engineering and Technology 2011

5 February 2011

doi: 10.1049/el.2011.0338

One or more of the Figures in this Letter are available in colour online.

C. Huang and S. Chakrabarty (Department of Electrical and Computer Engineering, Michigan State University, East Lansing, Michigan, USA)

E-mail: shantanu@egr.msu.edu

## References

- 1 Barver, W.L., and Brown, E.R.: 'A true logarithmic amplifier for radar IF applications', *IEEE J. Solid-State Circuits*, 1980, **15**, (3), pp. 291–295
- 2 Gilbert, B.: 'Translinear circuits: a proposed classification', *Electron. Lett.*, 1975, **11**, (1), pp. 14–16
- 3 Seevinck, E., and Wiegierink, R.: 'Generalized translinear circuit principle', *IEEE J. Solid-State Circuits*, 1991, **26**, (8), pp. 1098–1102
- 4 Chakrabarty, S., and Cauwenberghs, G.: 'A sub-microwatt analog VLSI trainable pattern classifier', *IEEE J. Solid-State Circuits*, 2007, **42**, (5)
- 5 Vittoz, E., and Fellrath, J.: 'CMOS analog integrated circuits based on weak inversion operations', *IEEE J. Solid-State Circuits*, 1977, **12**, (3), pp. 224–231